

## Warranty

Your Denali headset comes with a warranty registration card. To help ensure that headset warranty is registered with us, locate the serial number under the black stirrup that holds the right side ear cup. This would be the "non-boom" side of the headset. Make sure the number is preceded by a "s/n." Write the serial number on your warranty card and return it to us, or register online at [www.flightcom.net](http://www.flightcom.net).

Flightcom Corporation warrants to the original purchaser of this product that it will be free from defects in materials and workmanship, under normal and proper use, for the period of three years from date of purchase (excluding ear seals which are warranted for one year). Flightcom Corporation will repair or replace, at its sole option, any parts showing factory defects during this warranty period, subject to the following provisions. This warranty applies only to a new product, which has been sold through authorized channels of distribution. All work under warranty must be performed by Flightcom Corporation. All returned products must be shipped to our address, freight prepaid, accompanied by a dated proof of purchase. **SAVE YOUR SALES SLIP!**

The purchaser voids this warranty if he, she or others attempt to repair, service or alter the product in any way. This warranty does not apply in the event of accident, abuse, improper installation, unauthorized repair, tampering, modification, fire, flood, collision or other damage from external sources, including damage which is caused by user replaceable parts (leaking batteries, etc.). This warranty does not extend to any other equipment or aircraft to which this product may be attached or connected. The foregoing is your sole remedy for failure in service or defect. Flightcom Corporation shall not be liable under this or any implied warranty for incidental or consequential damages, nor for any installation or removal costs or other service fees. This warranty is in lieu of all other warranties, express or implied, including the warranty of merchantability or fitness for use, which are hereby excluded. To the extent that this exclusion is not legally enforceable, the duration of such implied warranties shall be limited to three years from date of purchase. No suit for breach of express or implied warranty may be brought after three years from date of purchase.



7340 SW Durham Road • Portland, Oregon 97224 USA  
800-432-4342 • 503-684-8229 • fax: 503-620-2943  
e-mail: [sales@flightcom.net](mailto:sales@flightcom.net) • web: [www.flightcom.net](http://www.flightcom.net)

Copyright ©2006. Denali is a registered trademark of Flightcom Corporation.  
Flightcom is a registered trademark of Flightcom Corporation. All rights reserved.  
Printed in U.S.A. Specifications subject to change without notice.

600-0033-20 Rev.C.

# Denali® Aviation Headset

## User Guide for Passive & Active Noise Canceling Models



For the fun of flying.



## Denali® Aviation Headset

### User Guide for Passive & Active Noise Canceling Models

Congratulations on your purchase of the Flightcom Denali aviation headset. Our extremely lightweight headset offers exceptional active and passive noise attenuation, a secure and comfortable fit, and extremely reliable performance.

Denali's Active Noise Reduction (ANR) model also comes factory direct with our Sure Power System (SPS), a digital power management circuit. The SPS conserves battery life by shutting off the ANR circuit when not in use.

The Denali is engineered to fit unlike any other aviation headset, providing excellent passive and active noise attenuation, a secure and comfortable fit, and extremely reliable performance. Because Denali offers such unique fitting adjustments, especially in the gimbal rotation of each of the canted ear domes, it is extremely important to take the time to review the fitting instructions outlined in this guide. By reading the fitting instructions carefully, it will ensure that the headset fits you and your passengers properly every time you take off.

Good flying!  
Your Flightcom Crew

### Important User Information

**WARNING:** Do not store your Denali headset in temperatures that exceed 156° Fahrenheit. Do not leave it in the sun, or hanging on the yoke of your aircraft, or exposed in conditions where the surface area of the headset might exceed this high temperature.

Under certain conditions, a mic muff might be necessary. A mic muff is provided for your convenience.

We also recommend that in the interest of hygiene, you replace your ear seals at least annually.

### Fitting Instructions

Denali headsets accommodate the differences in head shapes and sizes of the pilot population through angled ear domes, the shape and surface area of the ear seal, low side force and a lightweight design. When worn properly, you will feel very little pressure on top of the head, which is a refreshing departure from the traditional fit and feel of an older style aviation headset.

Additionally, personalized fit adjustments can be made in the length of the headband, the rotation of each ear cup, both side-to-side and up and down, and the placement of the boom and microphone.

### Personalized Headband Adjustments

- Hold the Denali headset in front of you. Place the dome that holds the mic boom in your left hand.
- Extend the headband to at least its midpoint to full extension. When you have reached the maximum headband extension, the headband slider will stop. Make sure you have extended the headband equally on both sides.
- Place the headset on your head. If the domes feel as if they're sitting too low on your ears, starting on one side of the headset, move the headband slider to a smaller position, ensuring both sides are adjusted equally.



**IMPORTANT:** While wearing the Denali, you should feel very little pressure on top of your head. **THIS IS NORMAL AND OPTIMAL.**

If you're an experienced headset wearer, you may have a tendency to reduce the headband size until you feel a familiar pressure on the top of your head or at the top of your jawbone. For Denali, this indicates you've actually reduced the size of the headband too much. Extend the headband in a downward direction, on both sides, until the top of the headset seems to "disappear." Check for a secure fit by shaking your head from side to side. Denali should remain firmly in place—without creating undue pressure on the top of the head.



### Individual Ear Dome Adjustments

Denali's ear domes rotate not only in an up and down direction, but also from side-to-side. This allows for maximum adjustment around the ear and jaw area.

- Once the headset is in place, and the headband is adjusted properly, you may want to individually rotate the dome or ear cup around each ear, to determine the most comfortable position.
- If during an extended flight you start to feel a bit of a pressure point, adjust the ear cup or the length of the headband to restore comfort.

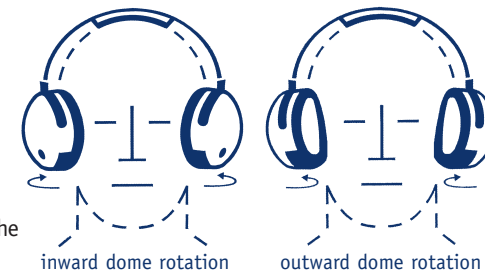

## Microphone and Boom Adjustments

- Adjust the mic boom for proper fit and comfort. Place the microphone no more than 1/8" from lips, at the corner of the mouth. This is critical to the performance of the noise-canceling electret microphone.

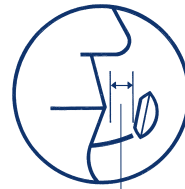

0-1/8" from lips

**IMPORTANT:** All Denali mic booms are shipped from the factory for wearing on the left side of the head only. Because the domes are canted to match the angle of the ears, the boom can ONLY be worn on the left side.

**CAUTION:** Rotating the boom beyond the "stop" will cause non-warranty damage to the boom.

## INSTALLATION

- Insert the larger headset plug into the jack marked "headphone" or "phone" (on your aircraft com panel, intercom or radio).
- Insert the smaller headset plug into the jack marked "microphone" or "mic."
- Set the stereo/mono switch on the cable splitter box to the "M" position. If connecting to a stereo intercom, set the switch to the "S" position.
- If you are not sure about the type of intercom in the aircraft, test the headset by selecting the "S" position and talking into the headset. If you hear sidetone out of one ear only, you have a mono intercom. Move the switch to "M."

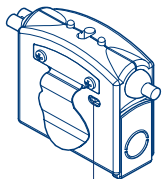

stereo/mono switch

- For the ANR model:** The stereo/mono switch is located on the back of the in-line battery box, near the clip.
- Adjust the headband sliders for proper fit and comfort, making sure the boom is being worn on the left side of the head.
- Individual volume controls are located on the front of each ear dome to reduce or adjust the level of audio in each headset ear cup.
- For the ANR model:** Once the 9-volt battery is installed, turn the ANR power to the ON position, indicated with the symbol "I." The OFF position is indicated with an "o." A blinking green LED indicates the active noise cancellation circuit is ON. A blinking red LED indicates low battery life. (For proper battery installation, see the diagram in the Care and Maintenance section of this guide.)

If the aircraft does not have a built-in push-to-talk (PTT) switch, a portable PTT switch must be installed in order to use the radio.

An avionics technician should optimize the master gain control located in the aircraft radio whenever adding a new model microphone to the system.

**Sure Power System (SPS):** To conserve battery life, ANR models will automatically shut off the ANR circuit if no audio is sensed by the headset for a period of 28 minutes. Full passive performance is maintained. ANR operation is reactivated by turning the ANR power switch to the OFF position and back to the ON position, indicated with the symbol "I."

## Care and Maintenance

### GENERAL CARE

As with most electronic equipment, it's important to protect your Denali headset from exposure to the elements. Do not leave the headset on the seat of the plane, car, or in intense, direct sunlight exceeding 156° F. Do not leave the headset out in the rain or in freezing temperatures. Return the headset to its carrying case and store in a cool, dry area.

**IMPORTANT:** Contrary to popular belief, wrapping the headset cords around the headband is not a proper storage method. In fact, by doing so you risk damaging the com cable, splitter, or battery box. Instead, loosely loop the headset cord in your hand and place the cable in the headset bag, next to the headset.

### GENERAL CLEANING

To clean the Denali headset, earseals, or headpad, dampen a non-abrasive cloth with water and mild soap. After cleaning, wipe dry with a soft cloth. Note: do not allow any water to seep into the ear dome.

**IMPORTANT:** Do not immerse the headset in water. Never use bleach on ear seals, headpad, or any other part of the Denali headset.

## Denali Ear Seal Removal and Installation

### REMOVAL

Your new Denali ear seals are permanently attached to the hard plastic backing plate. Do not attempt to remove the ear seal from the backing plate.

To remove the ear seal assembly, look inside the ear seal opening, half way down either side of the ear cup. You will notice a small cut-out just large enough to place your finger tip under the backing plate. Pull the backing plate (with the ear seal) away from the ear cup. Note: it will take a bit of force and the ear seal will pop off of the ear cup.

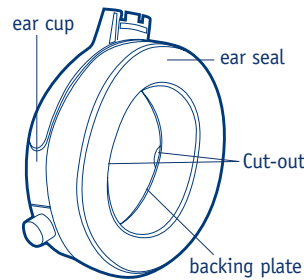

## INSTALLATION

Lay the gasket (for ANR models only) flat on the ear seals backing plate. The gasket must have no wrinkles. Carefully position the backing plate (with the gasket) on the ear cup and apply even pressure with your fingers spaced around the circumference of the ear seal/backing plate and then snap on to the ear cup. Note: the backing plate must not have any space between it and the ear cup.

## Denali Headpad Removal and Installation

Your new Denali headpad is permanently attached to the backing plate. Do not remove the headpad from the backing plate.

To remove the headpad, pull on each side of the headpad and it will snap out of position on the headset. To install the headpad, line it up to the top of the headset and then snap into position.

## Replacing the Battery

To install or replace the ANR battery, open the battery door by sliding the door in a downward motion until it unlatches and lift up as shown in diagram A.

Slide the 9-volt battery in with the larger battery contact on the bottom. If you put the battery in upside down, it will not activate. See diagram B.

Battery life is dependent on the ambient noise in the aircraft, but should provide a minimum of 20 hours of continuous use.

**CAUTION:** Bias voltage supplied to the microphone must come from voltage and resistance ranges specified below. Voltages supplied in excess of those stated in the specifications can cause microphone failure and void the warranty. The mic audio signal is present between the ring and barrel of the mic plug; tip is reserved for transmit keyline.

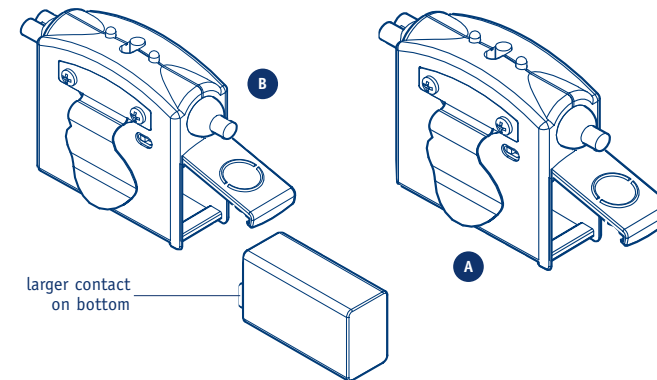

## Specifications

	Denali Passive	Denali ANR	
<b>Headset</b>	Shielding	Full floating w/independent ground	Full floating w/independent ground
	Weight	11.0 ounces	12.9 ounces
	Temperature Sensitivity	Not to exceed 156° F	Not to exceed 156° F
	Battery Life	Not applicable	20 hours of continuous use
<b>Speakers</b>	Origin	Made in USA	Made in USA
	Sensitivity(@1mW in dBspl)	104dB	
	Frequency Response	90Hz—20kHz	
	Impedance	300 ohms stereo/ch.—150 ohms mono	
	Total Harmonic Distortion (@1kHz)	<.15%	
	Maximum Power Input	250 mW	
	Noise Reduction Rating	21dB	
<b>Microphone</b>	Type	Noise canceling electret condenser w/constant-gain preamp	
	DC Bias Voltage	8-16 volts	
	Supply Source Resistance	220-2200 ohms	
	Frequency Response (± 6dB)	420Hz-6.4kHz	
	Sensitivity (@ 114dBspl*)	1.3V	
	Noise Rejection Ratio (@1kHz)	-46dB	
	Total Harmonic Distortion (@ 1kHz)	<0.3%	
	Impedance	500 ohms	
	Maximum Speech Level	112 dBspl*	
	Maximum Ambient Noise Level	132 dBspl*	

\*Sensitivity measurements referred to 0.0002 ubar (dynes/cm<sup>2</sup>) @ 1kHz. Microphone measurements made with 10-volt supply with a 1000 ohm resistor.

Contact Flightcom for the most current ANR specifications.

## Plug Connection Chart

