

FLIGHTCOM



DVR 300i

Digital Voice Recorder Clock



OPERATION AND INSTALLATION MANUAL

DVR® VOICE RECORDER

Rev. 2

Technical Specifications

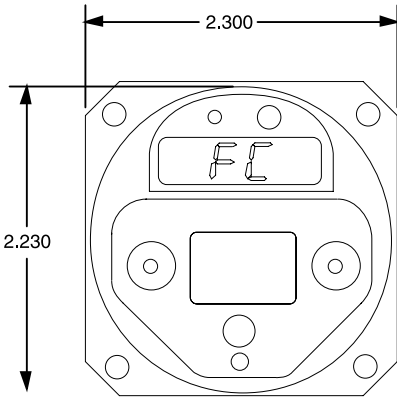

Mounting Screws 4-40 x 3/8

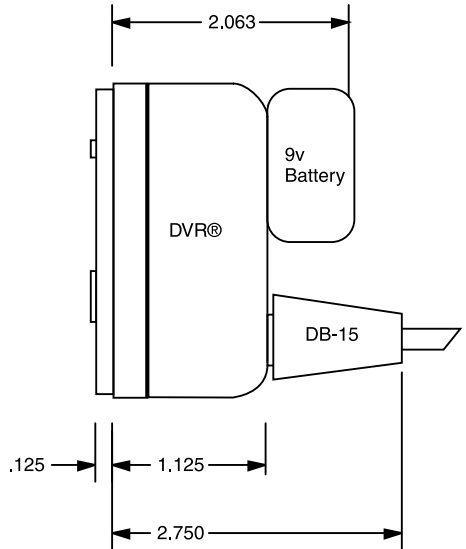

Total Recording Time	5 minutes
Standby Current Drain	.004 Amps typical
Active Current Drain	80 mA typical
Input Voltage	11 - 32 Volts DC
Speech Retention	30 days
Timekeeper Retention	3 years
Crystal Frequencies	2 MHz; 32.768 KHz
Weight (with battery)	5 ounces
Compliance	FAR 91.205
Limited Warranty	One Year



7340 SW Durham Road • Portland, OR 97224 • 503.684.8229 • Fax 503.620.2943
www.flightcom.net • service@flightcom.net

Flightcom and DVR are registered trademarks of Flightcom Corporation.
 ©2001 Flightcom Corporation.

Table of Contents

General Information	1
----------------------------------	---

Part I - Operation

Understanding the DVR Recorder	2
DVR Clock Layout	2
DVR Clock Operations	3
Turning on the DVR Clock.....	3
Setting the Time	3
Elapsed Timer and pseudo-Hobbs Meter.....	4
“Cron” Countup Timer.....	4
Recorder Operations	5
Automatic Recording and Playback.....	5
Manual Recording and Playback	5
Periodic Alarm System	6
Audio Checklists	6
Changing DVR Speech Quality	7
Backup Battery	8
Troubleshooting	8

Part II - Installation

Power Considerations	9
Audio Considerations	10
Mounting the DVR	11
Power Connection	11
Fig. 1 - Power Schematics	12
Audio Connections	13
Fig. 2 - Mono Audio Hookup	14
Fig. 3 - Stereo Audio Hookup.....	15
Testing the Audio Circuits	16
Volume Adjustment	16
Appendix 1: Mounting Template	17
Appendix 2: Master DB-15 Pinouts	18
Parts List.....	18

DVR Questions and Answers

Is the DVR Clock TSO'd?

No. At this time, there is no TSO specification for cockpit clocks. Companies such as Astrotech and Davtron have been installing non-TSO'd clocks in Part 135 aircraft for years, from 152's to Air Force One.

How do I get an installation approval?

Because the DVR Clock is placed in-line with your audio path, it is similar to an intercom installation. The installation of the DVR Clock is a modification to your aircraft, and you'll need to have a Form 337 filled out and signed by your avionics shop. Flightcom has sample 337's on file from previous installations and we can FAX you these if your particular FAA official is unfamiliar with the DVR recorders.

Suppose I don't want to record cockpit audio?

You could wire it between the radio and the intercom (see page 10) otherwise, the DVR Recorder has no way of distinguishing between your voice and the controllers. Therefore, your cockpit audio is recorded as part of the voice activated loop. Remember, though, that the endless loop accounts for only one minute of the total recording time, and it is written over with the next recording cycle. It does not "wear out" the recorder to constantly record all audio. Furthermore, you may want to hear what you told that controller.

What happens when I'm out of recording time?

The DVR never runs out of recording space with its endless loop. When one minute has been recorded, the oldest audio is pushed off the end, much like a digital conveyor belt. If you're recording a manual message or a checklist item, the DVR simply beeps and ceases recording when speech memory is exhausted.

Do my passengers hear the instant replay?

It depends on where you connect the audio (see page 10) and on which intercom you have installed, if any. If an intercom has good isolation between headsets (i.e. Flightcom), the pilot alone will hear the replay. If the intercom uses a common audio buss (i.e. Sigtronics), all passengers will hear the replay from the DVR.

General Information

As pilots, all of us have had to ask Air Traffic Control to “Say Again” at one time or another. Asking ATC to confirm a heading, repeat a squawk code, or reiterate a frequency can make a pilot look like an amateur.

The DVR® Clock is a 2 ¼" panel-mount **Digital Voice Recorder** and timekeeping device designed for commercial and general aviation use. When installed in your aircraft panel, the DVR Clock captures all ATC communications. You can replay missed or misunderstood clearances at any time, similar to the “instant replay” we see on TV football games.

Since the DVR is voice-activated, it doesn’t record the “dead air” between radio transmissions, making efficient use of its internal speech memory. This also means you don’t have to push any buttons to initiate recording, insuring all audio is captured automatically.

Each DVR Clock features:

- LOCAL OR ZULU TIME DISPLAY
- ELAPSED TIME DISPLAY (FLIGHT TIME)
- PSEUDO-HOBBS METER DISPLAY
- APPROACH TIMER
- UP TO 5 MINUTES OF DIGITAL VOICE STORAGE
- UP TO 32 VOICE CHECKLIST ITEMS
- NON-VOLATILE SPEECH MEMORY
- PERIODIC VOCAL REMINDERS
- NIGHT LIGHTING SYSTEM AND AUTO-DIM DISPLAY

Please read this guide carefully, and try out your new DVR Clock while you’re on the ground before attempting to fly with it.

Part I - Using the DVR® Recorder

After you've had your DVR installed by a qualified avionics technician, you should familiarize yourself with its functions while you're still on the ground. This way, using it in a busy cockpit environment will become second nature.

The DVR Clock was designed to be versatile, yet remain as simple as possible to operate. We have purposely not overloaded it with buttons or stuffed it with complicated time functions which we found most pilots don't use anyway.

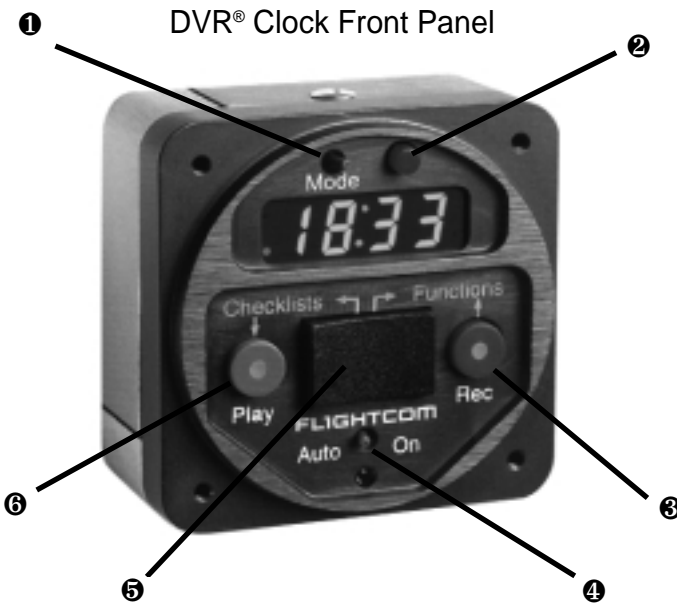

Throughout this guide, we'll be referring to the DVR switches as:

- | | | | |
|---|--------|---|-------|
| ❶ | MODE | ❷ | POWER |
| ❸ | TIME | ❸ | SKIP |
| ❹ | RECORD | ❹ | PLAY |

The DVR Model 300i has indicator lights on the buttons. Whenever these lights flash rapidly, it is a prompt that you may press the button to invoke a function. When the lights flash slowly, it means some function is being carried out.

Turning on the DVR® Clock

If your avionics technician has connected the aircraft battery to the DVR, you can turn the clock on by flipping the Power switch to the far right (“On”) position. This lets you work with the clock without turning on the avionics master switch.



IMPORTANT: Don't leave the power switch “On” if your aircraft battery is connected. This position is only for your pre-flight convenience in setting time, doing checklists, etc. The clock's 50 mA load will drain your aircraft battery if you forget about it and leave it “On” for several weeks.

Normally, the Power Switch should be in the “Auto” position, which powers up the clock only when you turn on the avionics master.

The center position of the Power switch is “Off.” If, for any reason you need to shut the DVR down, flip the switch to the center position.

Setting the Time

Your clock was shipped from the factory with Greenwich Mean Time (GMT or Zulu time) already set. You may have to set your local time.

To set local hours and minutes, make sure the Mode switch is in the far right position, displaying the time of day. Press and hold the Skip button, and while Skip is down, hit the Time button. You will see local hours begin to flash.

Now hit the Play or Record button to decrease or increase the local hours. When you have the correct hours displayed, hit Skip to go to the minutes setting. You may now hit the Record and Play buttons to change the minutes. When minutes are correct, hit Skip to advance to Zulu hours setting.

NOTE: If you change Zulu hours, you'll have to set local hours again.

Hitting Skip one last time will return you to normal time of day display and lock in your new time.

You may now toggle between Local and Zulu time by hitting the Time button. Local time is always displayed in 12-hour format, while Zulu time is in 24-hour format.

Elapsed Timer and pseudo-Hobbs Meter

The DVR® Clock begins timing your flight as soon as the unit is turned on. To display elapsed times, switch the Mode switch to the *center* position. All elapsed times are displayed in “hours.tenths” format.

Hitting the Time button while the Mode switch is centered will toggle between elapsed flight time and cumulative Hobbs time. The DVR “Hobbs” meter is a timer which logs all time that the DVR has been on. This is a fairly accurate way to keep track of how many total hours you have flown.

NOTE: The elapsed timer is cleared every time the clock is turned off. To clear the Hobbs meter, you must reset the clock. This means all previous programming will be erased, and you'll need to reset time etc. To reset the Hobbs meter, first turn the unit off, then press and hold down the time, play, record and skip buttons at the same time. Then turn the unit back on and reset the clock.

“Cron” Countup Timer

We have found count *up* timers to be more useful in the air than traditional countdown timers, which must be pre-loaded with a countdown time, usually during busy cockpit operations.

Moving the Mode switch to the far left puts the DVR into chronological countup timer mode. This is the only mode which displays running seconds, necessary for FAR Part 91.205.

Use this mode for timing turns, approaches, etc. Pushing the Time button in “Cron” mode zeros the timer. The timer will roll over to :00 after one hour.

Automatic Recording and Playback

The DVR Clock recorder uses a continuous loop which automatically captures all audio going into your headset. When incoming audio stops, so does the recorder. This way, communications are compressed for easy retrieval, and the oldest radio traffic is overwritten.

When you want to replay radio traffic, simply hit the Skip button. Each hit of the Skip button will “rewind” about 5 seconds and begin playback. If a live transmission comes in while you’re listening to the DVR, playback audio is automatically mixed with live audio.

You may stop playback at any time by hitting any button except Skip. Automatic recording resumes as soon as playback stops.

The DVR Clock has an audio monitor feature. When audio is detected, the red LED on the Record button flickers. This indicates that audio is being properly detected and recorded.

Manual Recording and Playback

Sometime during your flight, you may want to record material which you don’t want overwritten by cockpit conversation or other radio traffic - for examples, in-flight weather briefings, IFR clearances, or ground control taxi instructions.

The Record and Play buttons give you up to a minute of “digital notepad” recording and playback which is independent of the automatic recording area.

To record a message manually, hit the Record button. To stop recording, hit any button. (The DVR will stop by itself if it runs out of speech memory).

To play back your message, simply hit the Play button. The Skip button will skip back 5 - 10 seconds if you want to repeat part of this manual message. To stop playback, hit any button except Skip.

Periodic Alarm System

The DVR Model 300i has a built in alarm system which can play a reminder every few minutes. You can record a 5-second message which can be replayed in 5 - 90 minute intervals.

This is useful for important reminders such as “Switch fuel tanks” or “Cycle de-ice boots.”

To set the periodic alarm interval, get into the DVR *Functions* mode by holding down Skip and hitting Record. Now hit the Play or Record buttons to set the interval, going up or down in 5-minute increments.

When you are done, hit Skip to get into periodic alarm message mode. The display will say “PA:rP”, prompting you to record or play your periodic alarm message. Hit Record to record your message, and begin speaking after you hear the beep.

Hit Play to hear the message you just recorded. You may record and replay your message as many times as you’d like until you’re satisfied with it. Hitting Skip now will get back into normal time mode.

From now on, your message will sound twice at the interval you have set. You may turn it off again by getting back into functions mode and setting the interval time to zero.

NOTE: Live radio traffic will not be recorded in the instant replay section while you are setting or listening to the periodic alarm.

Audio Checklists

You can record up to 32 checklist items with the DVR 300i. These have been partitioned into 4 groups of 8 items, which makes it easier to skip between checklists. You may, however, group your checklist items in any way you see fit for your particular aircraft.

To get into checklist mode, hold down Skip and hit the Play button. You will see “CL1.1” on the display, meaning Checklist 1, Item 1. You can now record this item by hitting the Record button, and play it back immediately by hitting Play. The first checklist item should usually be the checklist title, such as “Before takeoff checklist.”

Once you have recorded a checklist item, you may not record over it until you deliberately erase it. Erase the item by holding down Record and then hitting Play.

When you are satisfied with the item, you may advance to the next item by hitting Skip.

You may also skip to the next checklist by holding down Skip and hitting Play. It is also possible to “back up” to the first item of the current checklist by holding down Skip and hitting Record.

Exit checklist mode by hitting the Time button.

NOTE: Live radio traffic isn't recorded in the instant replay section while in checklist mode.

Changing DVR Speech Quality

All DVR recorders have 3 voice qualities from which to choose: Best, Good, and Compressed. Consult Table 1 for speech qualities and their associated recording times.

NOTE: Changing speech quality erases all audio information and initializes the DVR speech memory.

To change speech qualities, you must power the unit up while holding down either the Play, Skip, or Record buttons. Holding down Play gives Compressed, Skip gives Good, and Record returns to the factory default of Best.

<i>Table 1</i>	Loop Record	Scratchpad Record	Periodic Alarm	Checklist Item
Best	37 secs	33 secs	4.5 secs	2.4 secs
Good	60 secs	54 secs	7.5 secs	3.8 secs
Compressed	68 secs	61 secs	8.5 secs	5 secs

9-Volt Backup Battery

The DVR 300i comes with a 9-volt backup battery to preserve checklist and speech data in case the clock is removed from the airplane. The battery will maintain speech data for 1-2 months. It is attached to the clock with a high-strength Velcro, which actually withstands more g's than a metal battery clip! In the unlikely event of an accident, the most recent radio traffic will be preserved.

Troubleshooting

The DVR was designed to be maintenance-free, requiring only a one-time volume adjustment. In rare cases, however, it may be possible for the unit to “lock up” in noisy aircraft power environments.

If your unit appears to be hung up, you can reboot the system by switching the power to Off (center position), and switch it on again while holding down the Time button for 5 seconds. This process will erase all checklists and other audio within the unit.

Part II - Installation

IMPORTANT NOTICE

Although simple to install, DVR recorders are sophisticated electronic devices which require careful installation. A qualified avionics technician is required to complete this work.

Effective July 1, 1994, Flightcom Corporation will not replace units damaged from installations by unqualified personnel. If you're unsure about installation procedures, please seek out an avionics shop and have the work done there.



Be sure to ground yourself by touching something metallic on the aircraft before handling any of the wires connected to the unit.

Power Considerations

The ideal installation for the DVR® is to have both an Avionics Master power source and a “keep alive” battery voltage source (remember that the 9 volt back up battery will only keep the speech memory alive for about two months - see page 8). Both supplies must be fused or have an in line breaker. If only the “keep alive” voltage is available and an additional switched source is not, then the pilot will need to manually turn the DVR on and off at the unit. Here are a few things to consider before planning the power connections and estimating the time required to install it:

Is the existing clock a windup? (If replacing a clock with the DVR®300i.)

- Yes** This could mean that there is no accessible power for the DVR, and power wires from the battery and or the breaker panel will need to be connected.
- No** This means there is probably at least one source of power for the DVR. It still may be necessary to run a power wire from the battery or from the breaker panel.

Audio Considerations

Since the DVR is a unique and flexible device, there is not a standard connection scheme for the audio circuit. The DVR is connected between an audio source and its original destination, i.e. an intercom and a headset. Whatever audio is present at the destination is now available to the DVR for recording. Likewise whatever the DVR records is played back to that same destination. The closer the DVR is installed to the Com radio, the less audio sources are available for recording. The closer the DVR is installed to the headset the more audio sources are available for recording.

If the DVR were to be installed between one radio and the audio panel (A) then only that radio's audio would be recorded. But the playback would be available for switching with the audio panel and broadcast through the cabin speaker or the entire intercom system. If the DVR were to be installed between the intercom and the pilot's station headset jacks (C) then whatever audio source was switched with the audio panel and whatever intercom audio was being heard by the pilot, including his own sidetone, would be recorded. But the playback would only be available to the pilot.

DVR 300i Typical Connection Configuration

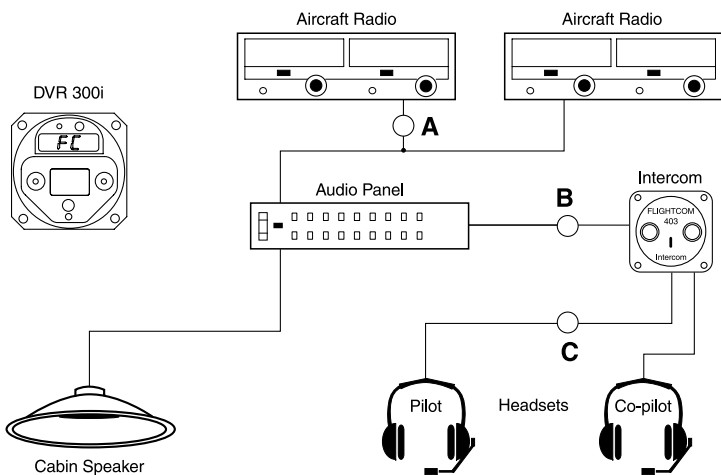

DVR 300i Connection

Location Selection Criteria

	Position A	Position B	Position C (Normal)
PRO	Playback through either speaker or headphones.	Record all radios and playback through all headphones.	Playback through only one headphone.
CON	Record only one radio. Must program checklists through radio sidetone.	Can't record intercom. Must program checklists through radio or audio panel sidetone.	Records all intercom conversations.

Mounting The DVR

If you are installing a DVR Clock, the panel cutout is designed to match a standard 2 1/4" panel hole. See Appendix I for proper dimensions and screw locations. The unit is back-mounted into the aircraft panel, with optimum .125" panel thickness.

Power Connection

The DVR accepts 11 - 32 volts with no modifications necessary. It is preferable to have the aircraft battery connected to the unit, but not required. If no aircraft battery is available, ATC traffic and checklist data may be lost if the aircraft is shut down.

All connections are made through the male DB-15 connector on the back of the unit.

Fig. 1 - Powering the DVR Recorder

Option I - Aircraft Battery Available – “Preferred”

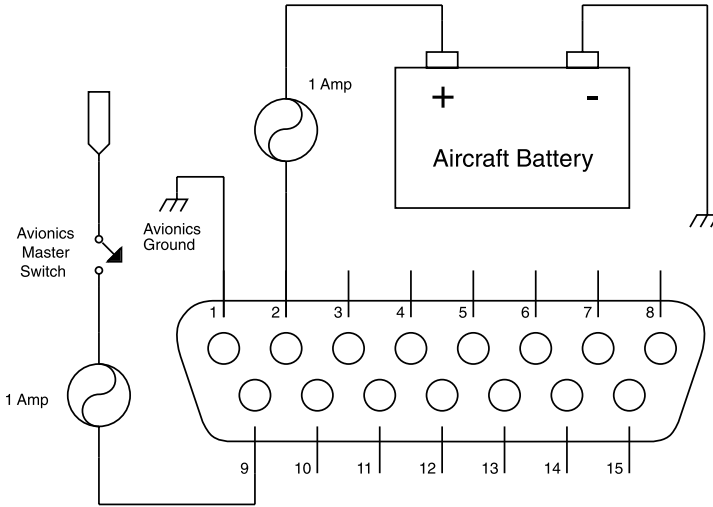

Option II - Aircraft Battery NOT Available

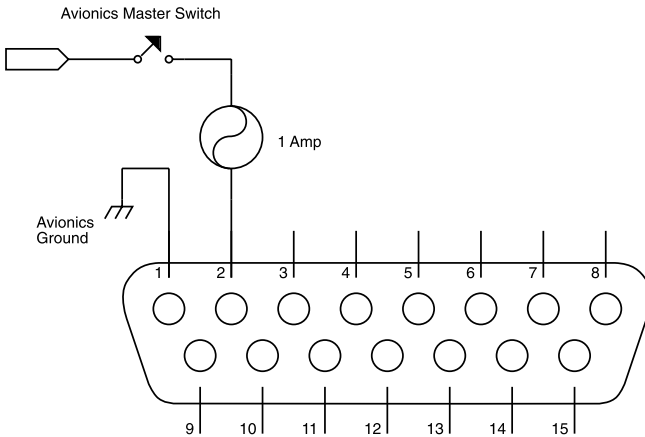

After making one of the above connections, you need to confirm that power is getting to the unit. With the DVR Clock, this is easy: simply turn it on and watch the display light up.

If nothing seems to be happening, check the voltage at Pin 2, using Pin 1 as ground reference. The DVR needs 11 - 32 volts DC to turn on.

Audio Connections

The DVR patches in series with the pilot headphone connector. Leave all microphone lines alone - they are not needed for any DVR functions.

All audio signals are passively patched through the DVR, so audio throughput is fail-safe. In the event of a complete DVR failure, audio will always make it to the pilot's headset. However, if you ever need to remove the DVR for service or update, you must plug in the supplied by-pass DB-15 plug to maintain continuity of aircraft audio signals.

Most aircraft audio systems use 1/4" female headphone jacks to get audio into the pilot's headset. The jack terminology used is as follows:

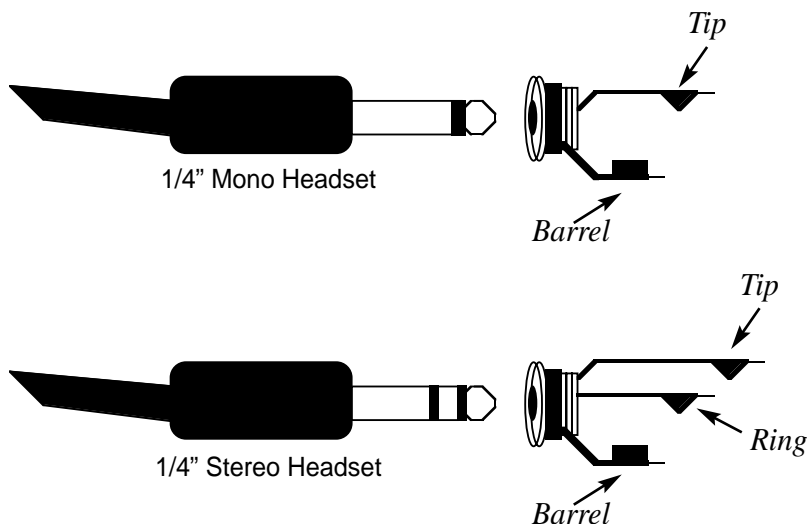

If your aircraft has a stereo intercom system, the DVR replays *recorded* audio through one ear while allowing the pilot to hear live audio in the other ear during a playback.

Fig. 2 - Audio Wiring for Mono System

(Position 'C' - page 10)

a) Typical Audio Wiring before DVR Installation

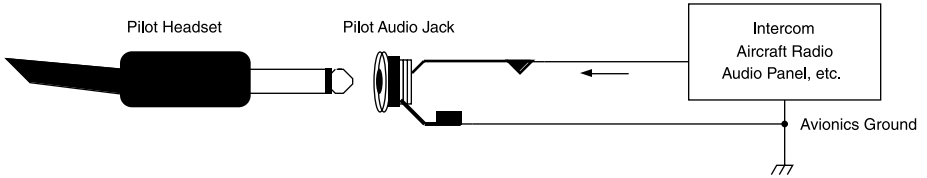

b) Audio Wiring Needed for DVR Recorder

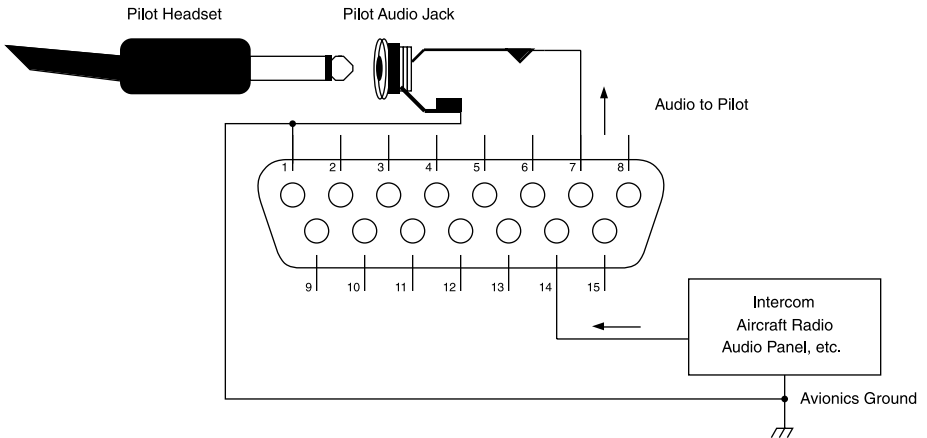

As mentioned earlier, the DVR needs to go in *series* with the headset audio, much like an in-line filter. The most straightforward way to do this is to disconnect the wire already at the tip connector of the pilot's headphone jack and connect it to DVR Pin 14.

Next, connect DVR Pin 7 to the pilot's headphone jack Tip, and connect DVR Pin 1 to the pilot's headset jack Sleeve and to avionics ground.

NOTE: It is important to have a common ground between audio signals. Some older aircraft audio systems may not be properly referenced to ground. In rare cases, an audio isolation transformer may be needed if garbled audio is heard through the DVR. Consult the factory for details.

Fig. 3 - Audio Wiring for Stereo System

(Position 'C' - page 10)

a) Typical Audio Wiring before DVR Installation

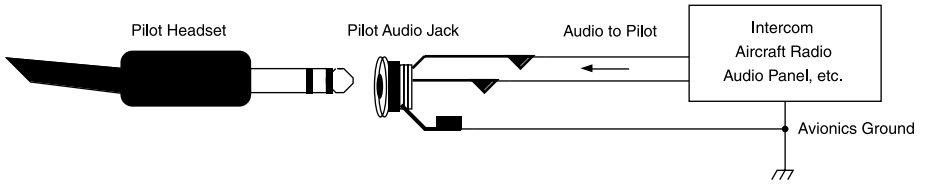

b) Audio Wiring Needed for DVR Recorder

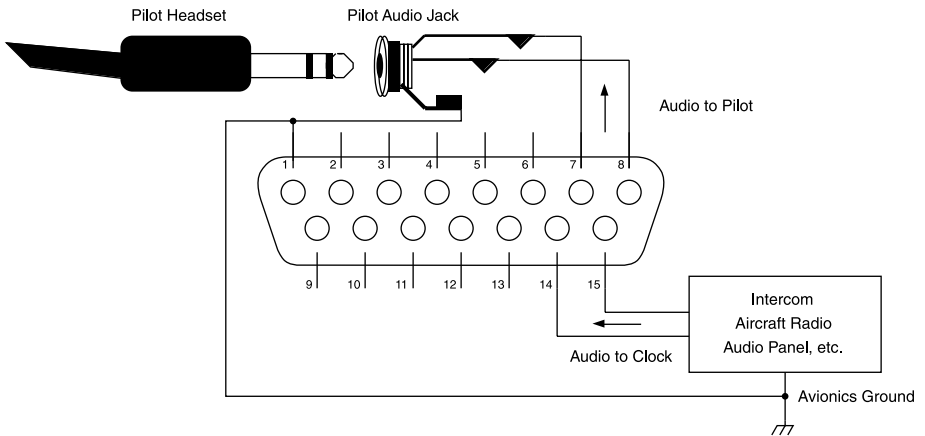

The primary difference between a mono and stereo installation is that you need to send BOTH audio channels through the clock when working with stereo.

Send the left audio channel of the stereo intercom to DVR Pin 14, and the right audio channel to DVR Pin 15. Then connect Pin 7 to the audio jack Tip, and Pin 8 to audio jack Ring. Again, make sure you have a common ground from the audio system to the headset.

When the pilot plays a message, replayed audio will be heard through one ear, while live radio traffic may be heard through the other.

Testing the Audio Circuits

Now that you have the audio routed through the clock, test out the system by plugging in a headset and checking for audio throughput.

Now power the unit up, press the "Skip" button, and listen for the acknowledgement beeps. If your headset is plugged in, the power is on, and you hear NO beeping when you hit Skip, then something is wired incorrectly. Refer to the wiring diagram and check your work.

When you hear audio thru the headset, the DVR should immediately begin recording it. Check this by hitting Skip and listen to the most recent audio. If the DVR is not recording, then once again, check that your wiring matches the diagrams.

Volume Adjustment

There is a small hole above the DB-15 connector for DVR playback adjustment. This has been set at the factory to replay radio traffic at about the same volume at which it was recorded. This trimpot may, however, need to be adjusted to account for variations in certain aircraft audio systems.

Warning: Don't twist or pry the volume pot or you will pop it off the PCB. Use a proper trimpot tool (plastic) for this adjustment.

To set the volume, power-up all avionics equipment as they would be during a normal flight. Record a manual message with the Record button and play it back, carefully adjust the volume with a trimpot tool such that the replay is at a comfortable level.

Once the volume is set, you should not have to adjust it again, and you may permanently mount the DVR.

Appendix 1 - Panel Cutout Template

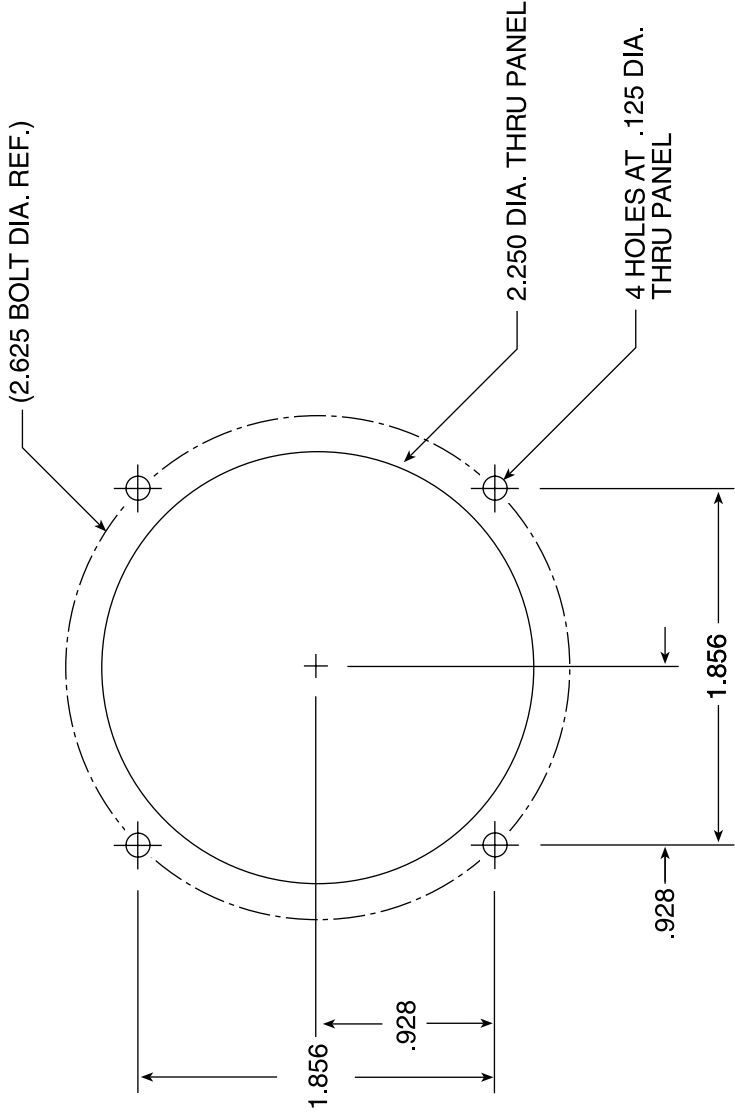

Appendix 2

DB-15 Pinouts

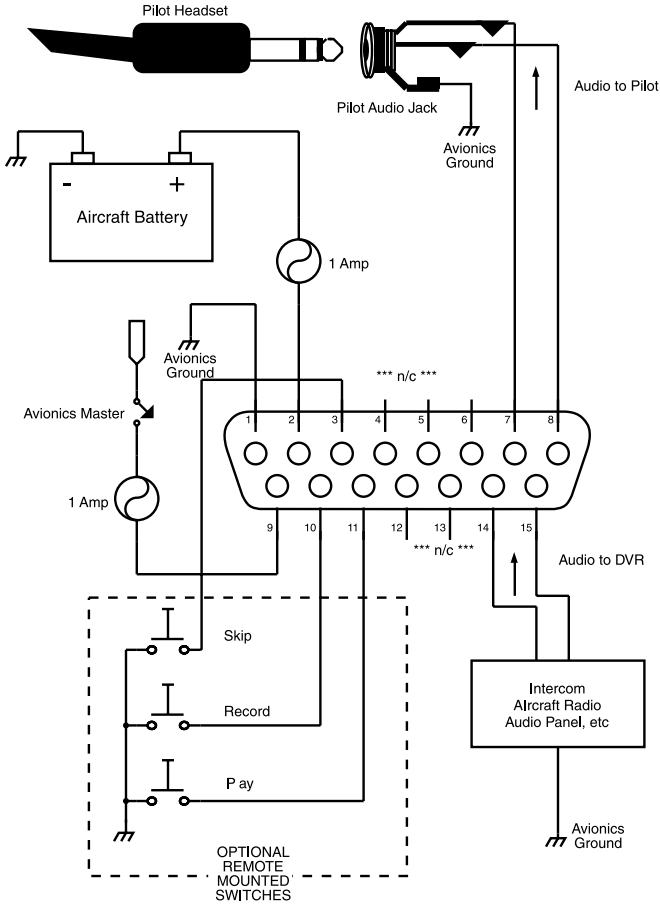

Parts List

- | | |
|----------------------------------|---------------------------|
| 1 DVR 300i | 1 By-pass DB-15 plug |
| 1 15 pin D-sub connector | 1 Velcro strip |
| 1 15 pin D-sub connector housing | 1 9-volt alkaline battery |
| 4 4-40 mounting screws | |

By-Pass Plug Wiring Diagram

