

MODEL 710

Ground Support Intercom

INSTALLATION/OPERATION MANUAL



FLIGHTCOM 

TABLE OF CONTENTS

Overview	2
Features	3
Installation	4-7
Operation	7
Troubleshooting	8-9
Options and Accessories	10
Appendix A-Wiring Diagrams	10
Appendix B-RJ Connector Assembly	11
Warranty	12

OVERVIEW

Flightcom's 710 intercom is designed for use in rugged, demanding environments. Providing clear communications between up to three occupants and a 2-way radio, it is ideal for mobile equipment with complex internal and external communication requirements and high-noise environments. When used with Flightcom noise attenuating headsets, the system provides protection from hearing loss that occurs from exposure to high-noise levels. The 710 intercom is a durable solution for airport ground support applications.

Headsets used with the 710 intercom system are interchangeable with other airport ground support systems that utilize the same standard three conductor plug configuration. All headset users experience simultaneous full-duplex, hands-free communications when used with the 710 intercom system. Individual headsets determine audio transmission with the push of a button, as well as independent volume control.

When connected to a radio, all participants will hear the radio traffic and only those set up to transmit will transmit over the radio.

FEATURES

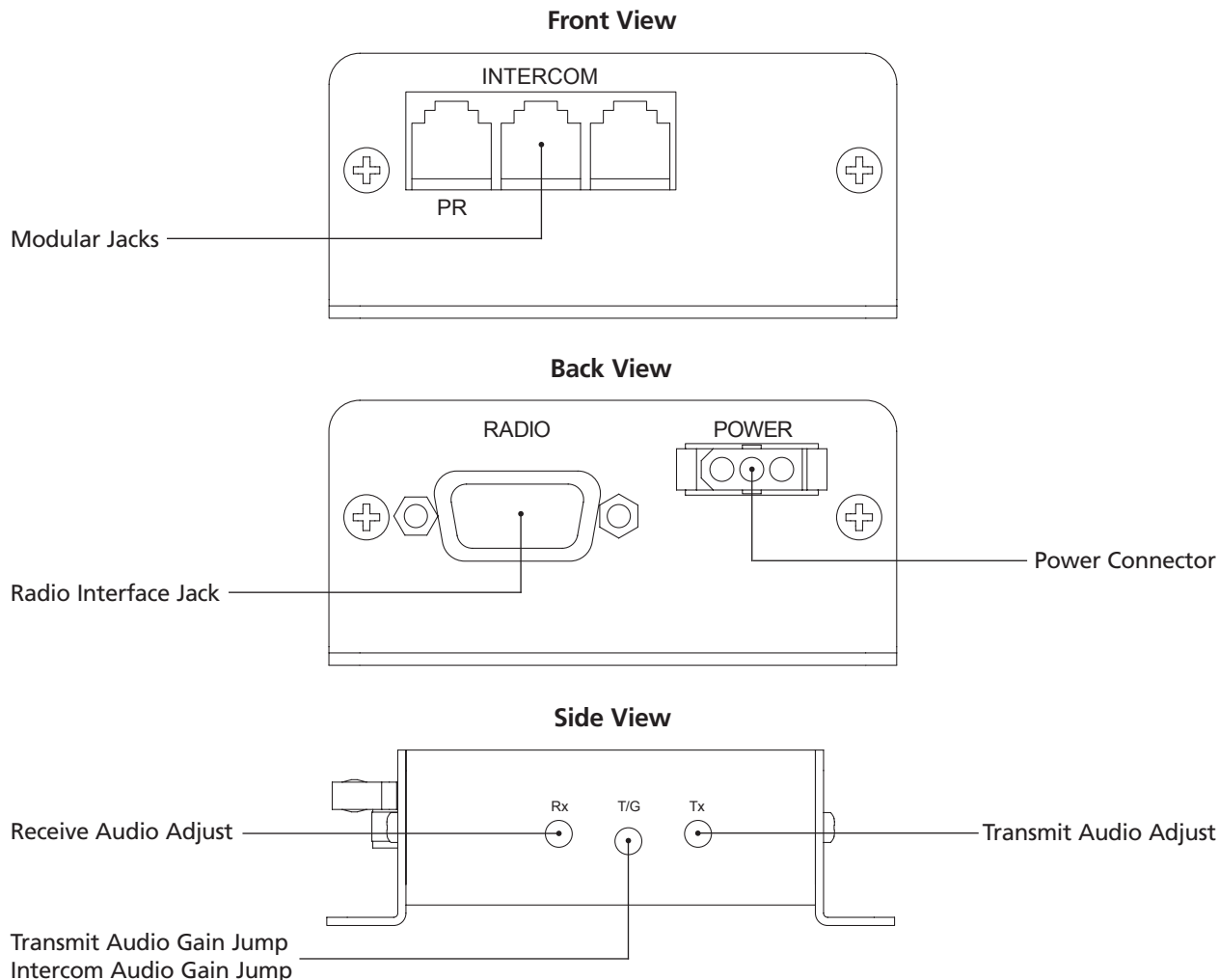

Modular Jacks

The modular jacks are the connection points for headset jacks or headset modules.

Radio Interface Jack

The 9-pin D-Sub connector is an attachment point for the enclosed mobile radio (MR) interface cable option.

Power Connector

The 3-pin connector is for attachment to vehicle power. A power connection cable is provided.

Receive Audio Adjust

A rotational adjustment for setting the level of audio received to the intercom from a mobile radio.

Transmit Audio Gain Jump / Intercom Audio Gain Jump

Two dip switches are provided for incremental gain increases of both the radio transmit audio and the intercom audio.

Transmit Audio Adjust

A rotational adjustment for setting the level of audio transmitted to an appropriate level for a mobile radio.

INSTALLATION

Mounting the Intercom

Mount the intercom unit to a flat surface by drilling four mounting holes and installing the enclosed #6 fasteners. Mounting hole and intercom dimensions are shown below. The unit is designed for indoor and vehicle interior use. Do not mount outdoors.

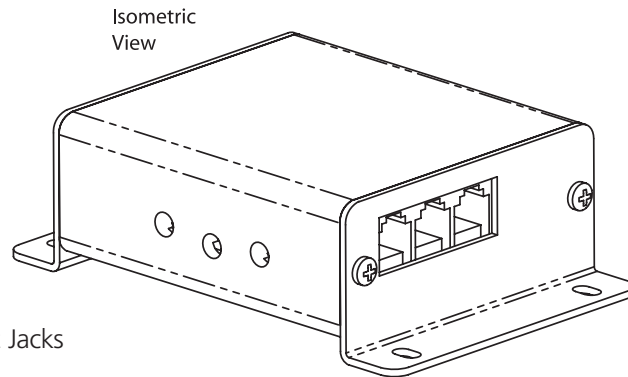

Assembly Shown without Jacks
Units: Inches [millimeters]
Scale: None

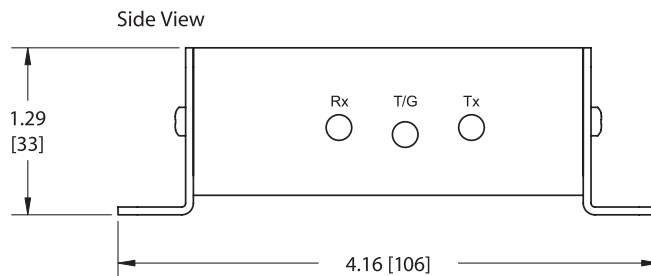
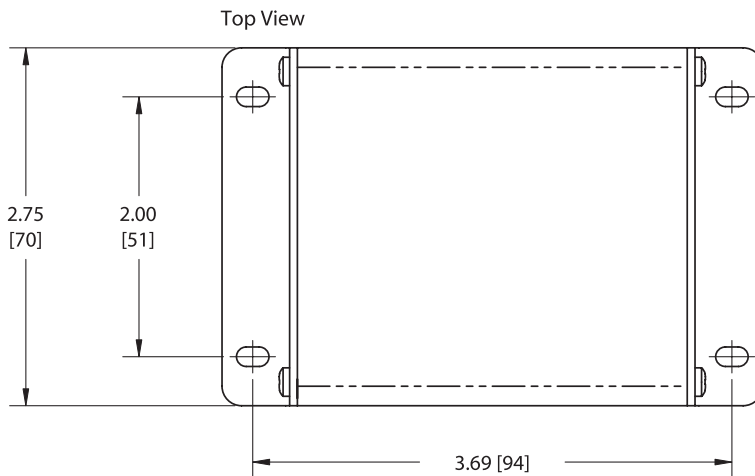

TROUBLESHOOTING

If the intercom system does not operate as expected, check the following items:

- Check for power at the intercom and confirm that the fuse (or circuit breaker) is not open.
- Check for corrosion on headset plugs.
- Check that headsets are plugged in all the way.
- Check headset volume control and PTT button.

If these steps do not correct the problem, review the chart below for symptoms and recommendations.

SYMPTOM	RECOMMENDED SOLUTION
Intermittent crackling in headset speakers	<ul style="list-style-type: none">• Check the headset plug. Make sure it is clean for the best electrical contact.• Check wire connections at the jack.• Check wire connections at the intercom.• Check the CA cable and RJ connectors. <p>Tip: Determine if the problem is with the headset or the headset jack by plugging the headset into another jack and re-testing.</p>
Alternator whine & other distracting noises	<ul style="list-style-type: none">• Confirm that all headset jacks are isolated from chassis ground using both the decal and fiber washer.• Confirm that the intercom power (-) is connected to a dedicated ground, not to the chassis.• Confirm that the remote cable shielding to headset jacks is grounded at one end, closest to battery ground.• Connect both the intercom and radio to the cleanest power source possible, without sirens, strobes, flashers, and motors (i.e. wipers, heater, etc.).• Check the power and ground connections for both the intercom and the radio. Make sure they are clean and tight.• Ensure that power and ground wires for the radio and intercom are no smaller than 18 AWG.• Check MR cable for proper wiring connections.• Make sure that all battery connections are clean and free from dirt and corrosion.• Use separate noise filters on radio and/or intercom power as needed.• Use a robust common ground for both the radio and the intercom. <p>Tip: Check the power to the intercom for an AC signal. There should be less than 300mVAC present on power lines.</p>
No sound in headset speakers	<ul style="list-style-type: none">• Check the volume control on the headset.• Check the headset plug. Make sure it is clean for the best electrical contact.• Confirm that the intercom has adequate power.• Check wire connections at the jack.• Check wire connections at the intercom.• Check the CA cable and RJ connector installation. <p>Tip: Determine if the problem is with the headset or the intercom system by plugging the headset into another jack and re-testing.</p> <p>Tip: Substituting suspect components in the system may be helpful in tracking down problems.</p>
You can hear others on the intercom, but they cannot hear you	<ul style="list-style-type: none">• Press the PTT button on your headset. See the Operation section of this manual for PTT activation details.• Check the headset plug. Make sure it is clean for the best electrical contact.

TROUBLESHOOTING

You can't hear others on the intercom, but they can hear you

- Check wire connections at the jack.
- Check wire connections at the intercom.
- Check the CA cable and RJ connector installation.

Tip: Determine if the problem is with the headset or the intercom system by plugging the headset into another jack and re-testing.

Tip: Substituting suspect components in the system may be helpful in tracking down problems.

- Check the headset plug. Make sure it is clean for the best electrical contact.
- Check wire connections at the jack.
- Check wire connections at the intercom.
- Check the CA cable and RJ connector installation.

Tip: Determine if the problem is with the headset or the intercom system by plugging the headset into another jack and re-testing.

Tip: Substituting suspect components in the system may be helpful in tracking down problems.

The headset speaker has sound from the intercom but not the radio or the radio receive audio is weak

- Check the radio volume
- Adjust the receive audio setting. See the **Installation** section of this manual.
- Verify that receive audio is present by listening to the radio's speaker.
- Check the MR cable between the radio and the intercom. Make sure the screws on the 9-pin D-sub connector are tight. See **Appendix A** for wire connection details.

The radio keys but no audio is transmitted or the radio transmitted audio is weak

- Check the affected headset location for faulty connections or components.
- Adjust the transmit audio setting. See the **Installation** section of this manual.
- Check the MR cable between the radio and the intercom. Make sure the screws on the 9-pin D-sub connector are tight. See **Appendix A** for wire connection details.

Tip: Determine if the problem is with the headset or the intercom system by plugging the headset into another jack and re-testing.

Tip: Substituting suspect components in the system may be helpful in tracking down problems.

The radio doesn't key

- Check the affected headset location for faulty connections or components.
- Check the CA cable and RJ connector installation.
- Check the MR cable between the radio and the intercom. Make sure the screws on the 9-pin D-sub connector are tight. See **Appendix A** for wire connection details.

Tip: Determine if the problem is with the headset or the intercom system by plugging the headset into another jack and re-testing.

Tip: Substituting suspect components in the system may be helpful in tracking down problems.

If a problem persists in a headset or intercom unit, contact Flightcom for a Return Merchandise Authorization (RMA) number. Return the headset or intercom for replacement or repair.

Contact:

Flightcom Corporation
7340 SW Durham Road
Portland, OR 97224 USA
800-432-4342 OR 503-684-8229

OPTIONS AND ACCESSORIES

See www.flightcom.net for options and accessories.

Specifications

Dimensions:

L x H x W: 4.16 [106] x 2.75 [70] x 1.29 [33] inches [millimeters]

Weight::

5.9 oz (without cables)

Power Requirements:

Minimum: 9.5 VDC @ 83mA

Maximum: 28.0 VDC @120mA

See the headset manual for headset specifications.

Appendix A - Wiring Diagrams

Standard Headset Jack

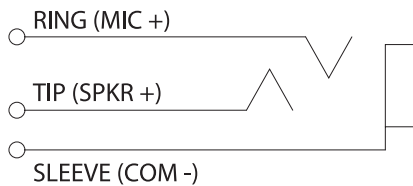

RJ-12 Plug

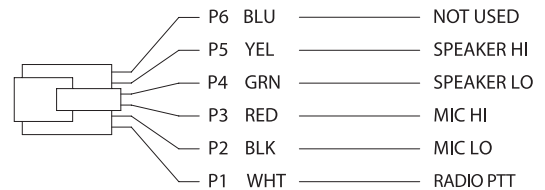

Mobile Radio Interface Cable

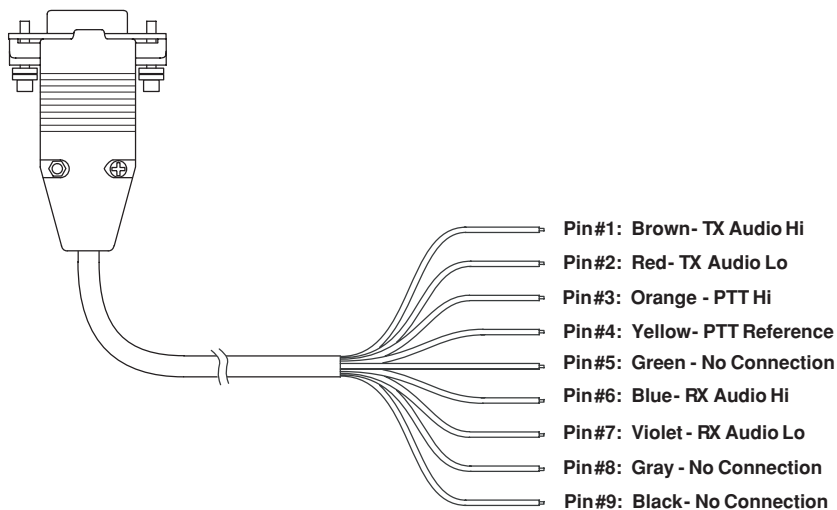

Appendix B - RJ Connector Assembly

RJ Connector, 6 Position Plug Installation

To install the RJ connector plug onto the flat CA cable:

1. Using the cutter blade on the crimping tool (labeled A, in figure 1), cut the CA cable so the cut is clean and at a 90-degree angle to the side of the cable.
2. Fully insert one end of the CA cable between the stripping blades (labeled C, in figure 1) until the end of the cable hits the stop (labeled B, in figure 1).

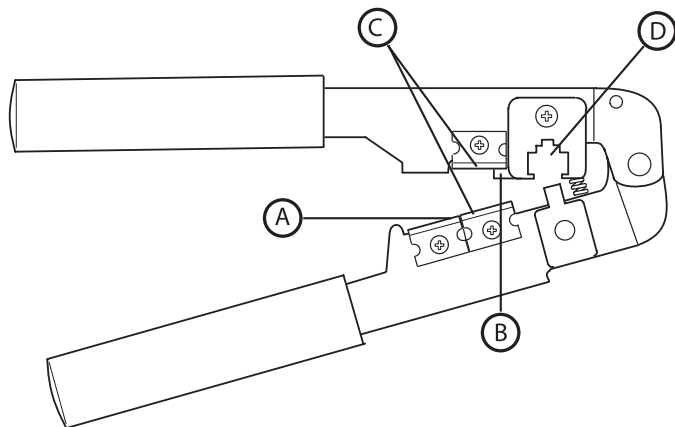

Figure 1
RJ Connector Plug
Crimping Tool

3. Squeeze the handles of the crimping tool together until the tool bottoms out.
4. While holding the handles together, pull the cable out of the tool.
5. The striped insulation should expose approximately 3/16" of wire (figure 2).
6. Push a RJ connector into the plug holder on the crimping tool (labeled D, in figure 1) until the release tab on the plug locks into position.
7. Holding the cable so that the printed side of the cable is toward the release tab on the plug, push the cable into the plug as far as it will go.

Figure 2
Stripped
CA Cable

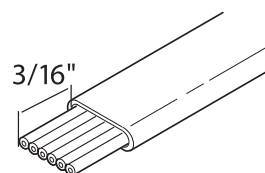
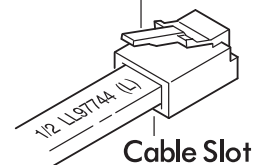

Figure 3
RJ Connector
Plug

Release Tab



Cable Slot

Note: Always make sure the printed side of the cable is facing the release tab on the RJ connector plug (figure 3). This ensures proper orientation of the plug on each end of the cable.

8. Squeeze the tool handles completely together. You may feel the crimper finish punching the contacts through the insulation on the wires.
9. Let the handles spring open.
10. Push down on RJ connector release tab (figure 3) and remove the RJ connector from the crimping tool.
11. Inspect the plug to ensure that the cable is held securely in place.
12. Repeat this procedure as necessary to install a RJ connector plug on each end of each CA cable.

WARRANTY

One-Year Limited Warranty to the Original Purchaser

Flightcom Corporation warrants to the original purchaser of this product that it will be free from defects in materials and workmanship, under normal and proper use, for the period of one year from date of purchase. Flightcom Corporation will repair or replace, at its sole option, any parts showing factory defects during this warranty period, subject to the following provisions. This warranty applies only to a new product which has been sold through authorized channels of distribution. All work under warranty must be performed by Flightcom Corporation. For warranty service, all products must be shipped to our address, freight prepaid, accompanied by a dated proof of purchase. **SAVE YOUR SALES SLIP!** The purchaser voids this warranty if he, she or others attempt to repair, service or alter the product in anyway. This warranty does not apply in the event of accident, abuse, improper installation, unauthorized repair, tampering, modification, fire, flood, collision or other damage from external sources, including damage which is caused by user replaceable parts (leaking batteries, etc.). This warranty does not extend to any other equipment or aircraft to which this product may be attached or connected. The foregoing is your sole remedy for failure in service or defect. Flightcom Corporation shall not be liable under this or any implied warranty for incidental or consequential damages, nor for any installation or removal costs or other service fees. This warranty is in lieu of all other warranties, express or implied, including the warranty of merchantability or fitness for use, which are hereby excluded. To the extent that this exclusion is not legally enforceable, the duration of such implied warranties shall be limited to one year from date of purchase. No suit for breach of express or implied warranty may be brought after one year from date of purchase. Register warranty on-line at www.flightcom.net.



Flightcom Corporation

7340 SW Durham Road, Portland, OR 97224 USA
www.flightcom.net • e-mail: sales@flightcom.net
800-432-4342 or 503-684-822

Flightcom is a registered trademark of Flightcom Corporation.
Specifications subject to change without notice. ©2007 Flightcom Corporation.