

MODEL 403 Panel-Mount Intercom

MODEL 403d Panel-Mount Intercom with Digital Clearance Recorder (DCR™)

INSTALLATION/OPERATION MANUAL



CONGRATULATIONS! You have just purchased the best value in "STATE OF THE ART" cockpit communication. This unit is equipped with many new convenient features that will add to your flying enjoyment.

PLEASE READ THIS MANUAL BEFORE USING THE INTERCOM AND CONSULT WITH YOUR A & P MECHANIC OR REPAIR STATION PRIOR TO INSTALLATION.

For the fun of flying.



SYSTEM OVERVIEW

Flightcom Intercom Models 403 and 403d are full dual-channel stereo capable units also compatible with monaural headsets. Installation of up to six places is possible with the jacks included with both models. Three of these six places have transmit capability over aircraft radios. Model 403d also includes the Digital Clearance Recorder (DCR™), which enables instant recall of voice information.

Figure 1 - Model 403/403d Typical Connection Configuration

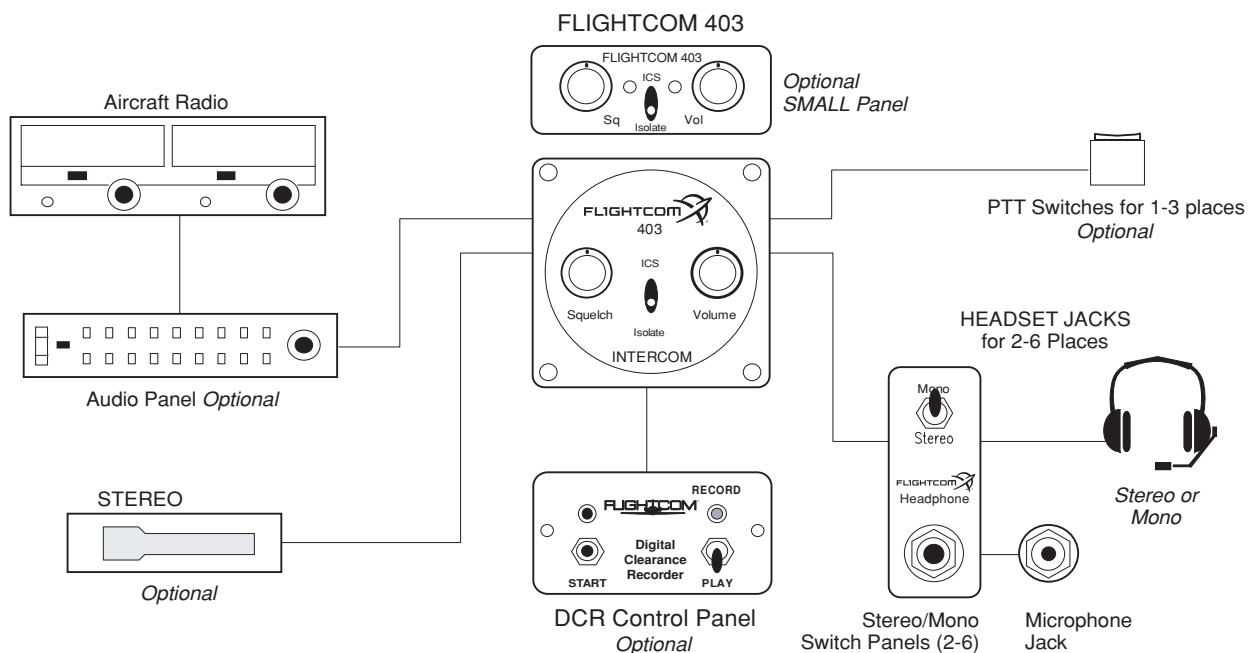

SPECIFICATIONS

Size: 5"L x 2.4"W x 1.2"H

Weight: 5.0/5.6 oz.

Output: 375 milliwatts into each channel of up to six 150 Ohm headsets. Sound level remains constant regardless of the number or the type of headsets connected. Power Requirements: 0.16 amps, 12-28 VDC
 Warranty: two year parts and labor

PARTS LIST

403 or 403d intercom, labeled

Accessory Package:

- 1 25-pin D-sub connector (male)
- 1 25-pin D-sub connector housing
- 1 Large control panel
- 1 Small control panel
- 2 Knobs
- 6 Stereo/mono switches with mounting nuts and washers
- 2 4-40 mounting screws
- 6 Stereo/mono control panels
- 4 6-32 screws
- 1 Allen wrench

Jack package:

- 6 Headphone jacks
- 6 Microphone jacks
- 12 Metal nuts
- 12 Metal washers
- 6 Black fiber shoulder washers
- 6 White nylon or fiber washers

Manual

Warranty Card

Model 403d also contains:

- 1 Wiring harness for DCR, with button, switch, and LED
- 1 DCR control panel
- 2 LED holders
- 2 Sheet metal mounting screws

SET-UP and INSTALLATION

Mounting the Intercom to the Aircraft

The 403 and 403d intercoms can be mounted to the aircraft in either of the following ways:

- Standard 2¼ inch Instrument Hole Mounting
- Through-panel or Under-panel Mounting

Standard 2¼ inch Instrument Hole Mounting

To mount the intercom with standard 2¼ inch hole mount:

1. Secure the intercom to the large control panel using the two hex nuts and washers located on each potentiometer control shaft (Figure 2 below).

NOTE: this is the only time when the potentiometer nuts and washers can be removed and replaced. Do not remove or use them to secure the intercom to the aircraft panel or to the small rectangular control panel.

CAUTION: the potentiometer control shafts are easily damaged after the hex nuts have been removed.

2. Attach the intercom/control panel assembly to the aircraft panel with four 6-32 non-magnetic screws.
3. Attach the **Volume** and **Squelch** control knobs to the screws, so that both knobs point to the 7 o'clock position when rotated completely counter-clockwise.

Figure 2 - Large Control Panel-Exploded View

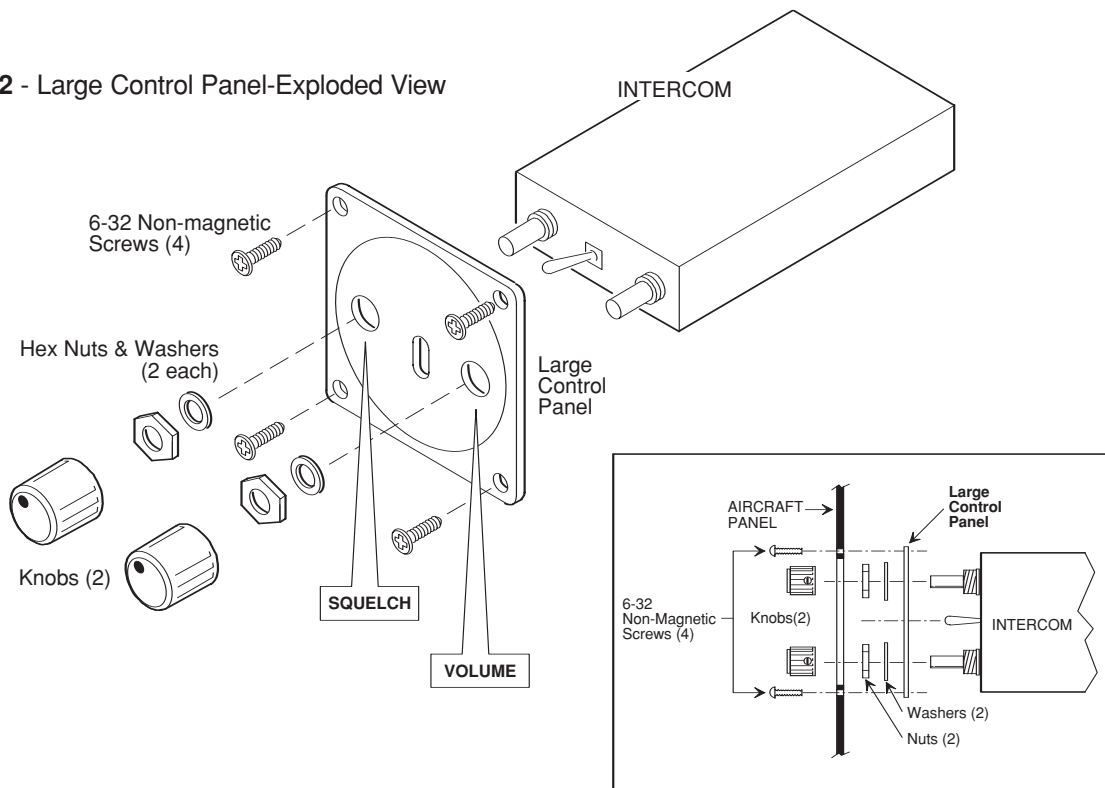

Through-panel or Under-panel Mounting

The intercom can be mounted in any 5.5 inch deep, 1.2 inch by 2.5 inch space. It can be placed either vertically or horizontally in or under the aircraft instrument panel or in any other accessible location in the aircraft.

For through-panel or under-panel mounting:

1. Leave the two potentiometer nuts in place on the intercom.
2. Place the small intercom control panel on the aircraft panel either vertically or horizontally (page 2, Figure 3), and use one of the drill templates shown in (Figure 4, page 2) to trace the location of the holes for drilling.
 - For panels less than .1 inch thick, use a 9/32 inch drill bit for the controls (use Drill Template #1 in Figure 4, page 2).
 - For panels between .1 and .2 inches thick, use a 1/2 inch drill bit or punch to clear the potentiometer nuts (use Drill Template #2 in Figure 4, page 2).

- 3 Insert the intercom through the aircraft panel and the small intercom control panel with the correct side facing outward.
 4. Attach the intercom and control panel to the aircraft panel using two 4-40 by 1/2 inch mounting screws.
 5. Attach the **Volume** and **Squelch** control knobs so that they both point to the 7 o'clock position when they are rotated completely counter-clockwise.
- CAUTION:** to avoid contact with parts inside the intercom, do not use screws longer than 1/2 inch.

Figure 3 - Small Intercom Faceplate Installation

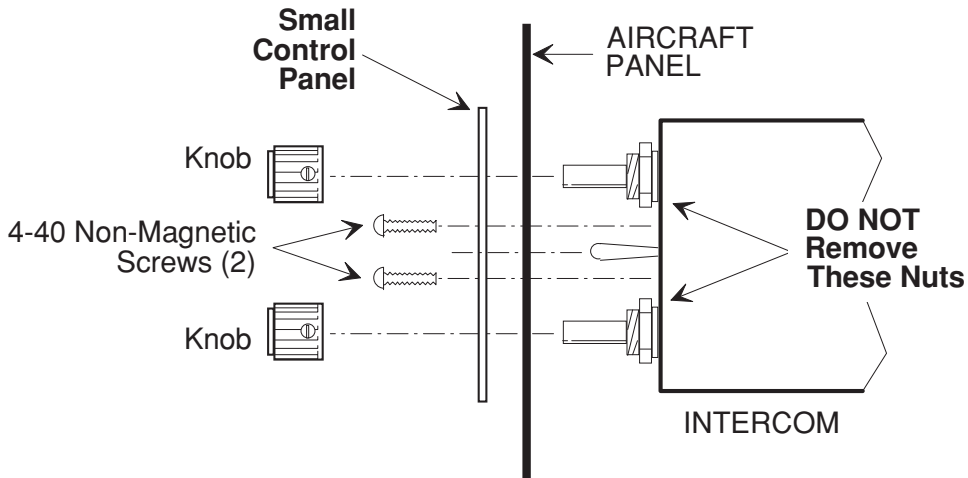
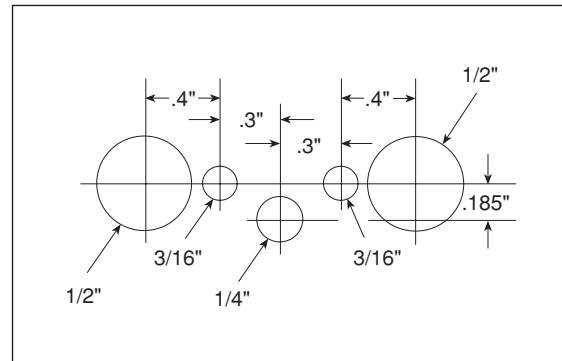
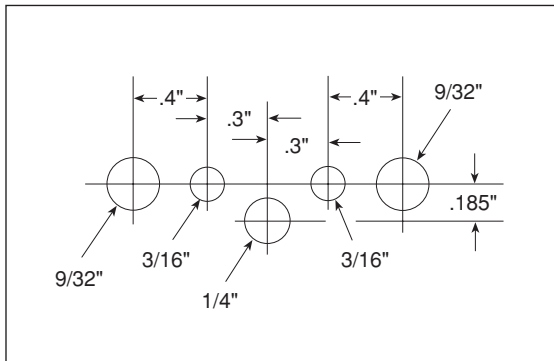

Figure 4 - Drill Templates



Headphone and Microphone Jack Installation

The 403 and 403d intercoms can be installed as either a stereo/monaural, monaural only, or stereo only system. With either type of installation you may leave the existing aircraft headphone and microphone jacks in place to use as a convenient tie in point at which to connect wires 8, 17, and 21 to the radio, or you may connect the intercom to an audio panel instead of the aircraft jacks. You can also use the existing jacks as a standby radio connection if you remove the intercom for servicing.

With all three types of installation, you must insulate the microphone jacks from the airframe, but you may either ground the headphone jacks to the airframe or insulate them with a separate ground wire running back to the intercom.

NOTE: do not use the same ground wire for headphone and microphone jacks, even when the ground wires are connected at the same location on the intercom.

Stereo/Monaural Jack Installation

The stereo/monaural installation is preferable because it allows stereo and monaural headsets to be used at the same time.

To attach headphone and microphone jacks to the aircraft panel when you are installing the intercom as a stereo/monaural system:

1. Choose an accessible location in the aircraft panel for each pair of headphone and microphone jacks (one pair each for the pilot and co-pilot and one pair each for up to four passengers).
2. Using the stereo/mono switch plate as a template placed either horizontally or vertically, carefully mark each stereo/mono switch and headphone jack location.
3. Drill one 1/4 inch hole in the aircraft panel for each stereo/mono switch and one 3/8 inch hole for each headphone jack (**Figure 5 below**).
4. Drill one 1/2 inch hole in the aircraft panel for each microphone jack shoulder washer, preferably next to the headphone jack.
5. Connect headphone and microphone jacks with 20-22 gauge wire (preferably 22 gauge), as shown in (**Figure 5 below**) and (**page 4, Figure 6**).
6. Pass the stereo/mono switch through the aircraft panel and switch plate, and secure it using the mounting nuts and washers provided (**Figure 5 below**).
7. Mount the headphone jack to the aircraft panel and switch plate, and secure it using the metal mounting nut and washer provided.
8. Repeat steps 3 through 7 at each pre-marked headphone jack location, with the correct side of each switch plate facing outward.

Figure 5 - Jack Mounting Diagram-Stereo/Mono

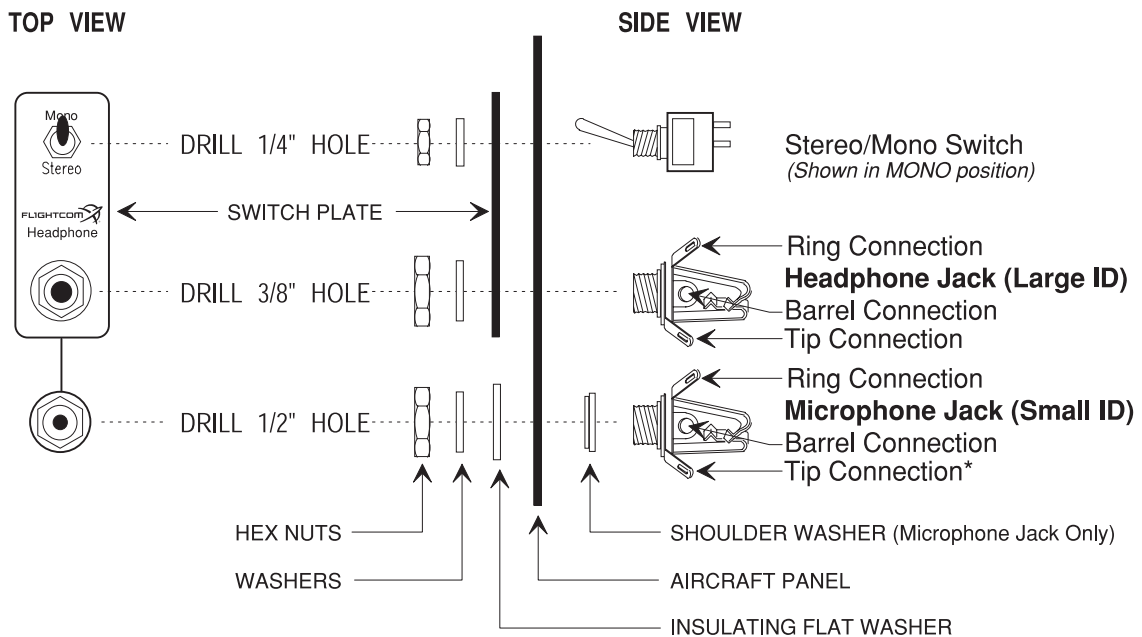

*Note: The tip connection of the microphone jack is only used for push-to-talk (PTT) wiring for pilot and co-pilot.

Figure 6 - Connection Schematic - Stereo Mode

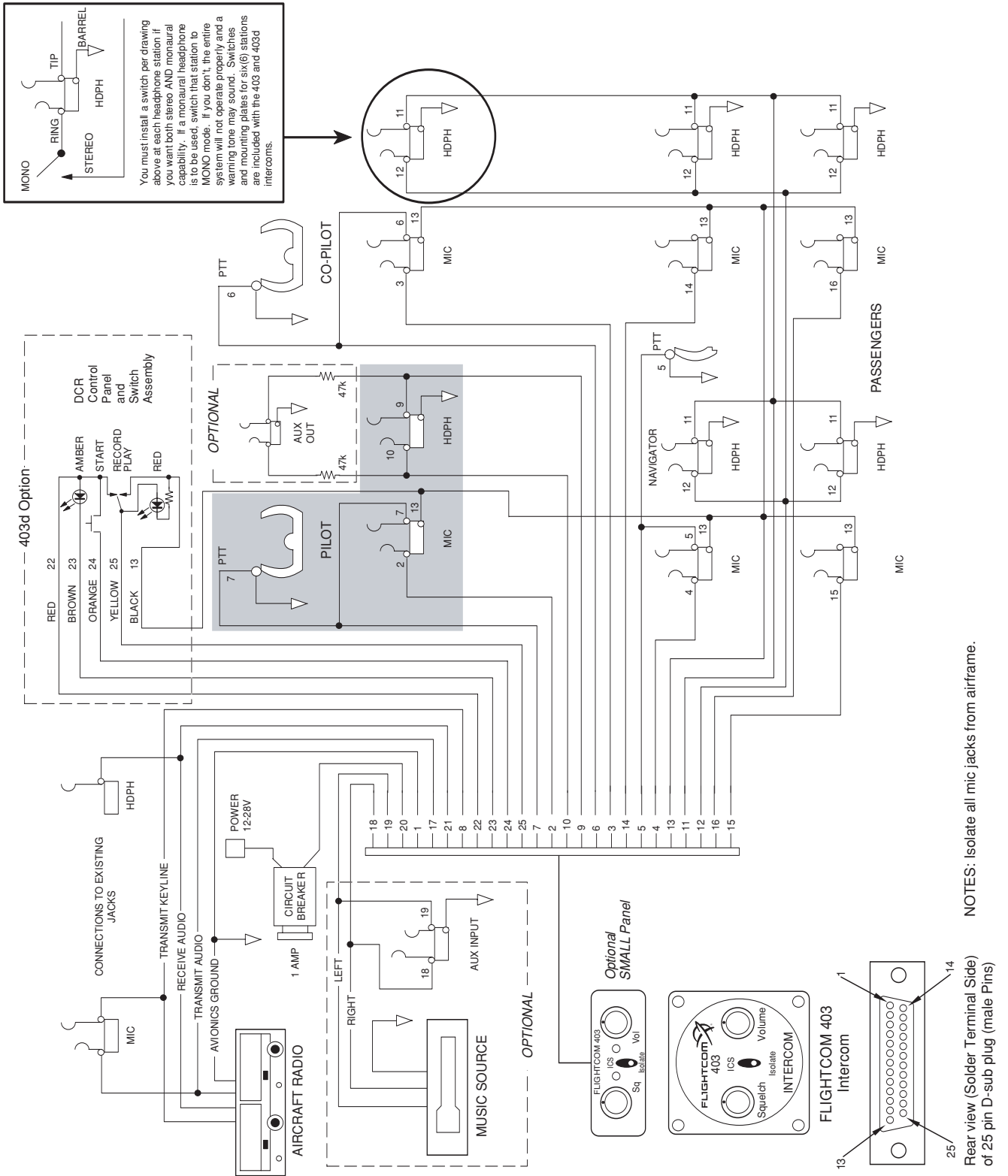

Monaural Only Jack Installation

If you are using a monaural only or stereo only system, you will not install stereo/mono switches and switch plates.

To attach headphone and microphone jacks to the aircraft panel when you are installing the intercom as a monaural only system:

1. Choose a location for each pair of headphone and microphone jacks (one pair each for the pilot and co-pilot and one pair each for up to four passengers).
2. Drill one 3/8 inch hole for each headphone jack (Figure 7 below).
3. Drill one 1/2 inch hole in the aircraft panel for each microphone jack and shoulder washer, preferably next to the headphone jacks.
4. Connect headphone and microphone jacks with 20-22 gauge wire (preferably 22 gauge), as shown in the (Figure 7 below and page 6, Figure 8).

Figure 7 - Jack Mounting Diagram-Mono Only or Stereo Only

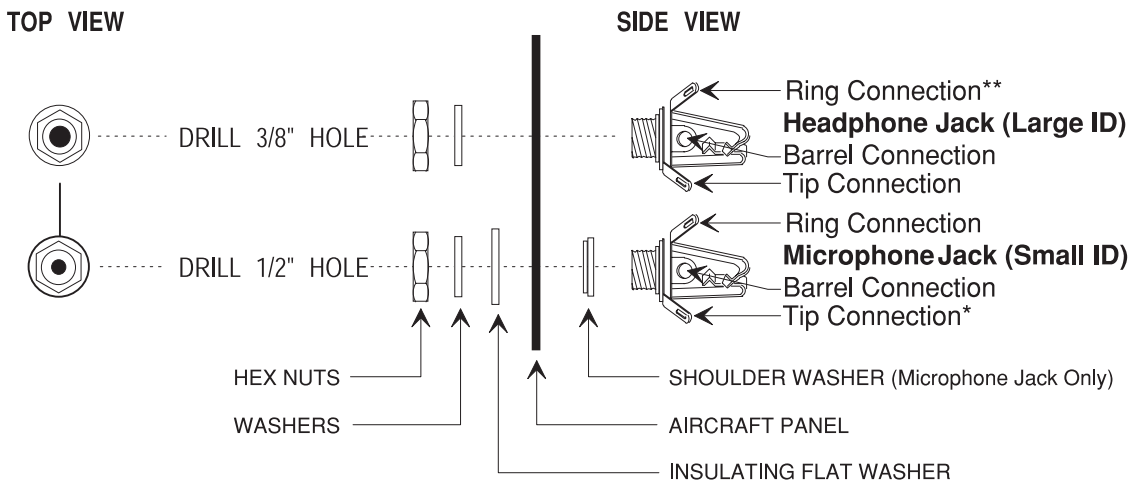

*Note: The tip connection of the microphone jack is only used for push-to-talk (PTT) wiring for pilot and co-pilot.

**Note: The ring connection of the headphone jack is not used in mono only installations.

Stereo Only Jack Installation

To attach headphone and microphone jacks to the aircraft panel when you are installing the intercom as a stereo only system:

1. Choose a location for each pair of headphone and microphone jacks (one pair each for the pilot and co-pilot and one pair each for up to four passengers).
2. Drill one 3/8 inch hole for each headphone jack (Figure 7 above).
3. Drill one 1/2 inch hole in the aircraft panel for each microphone jack and shoulder washer, preferably next to the headphone jacks.
4. Connect headphone and microphone jacks with 20-22 gauge wire (preferably 22 gauge), as shown in the Stereo Connection Schematic (Figure 7 above and page 4, Figure 6).

Figure 8 - Connection Schematic - Mono Mode

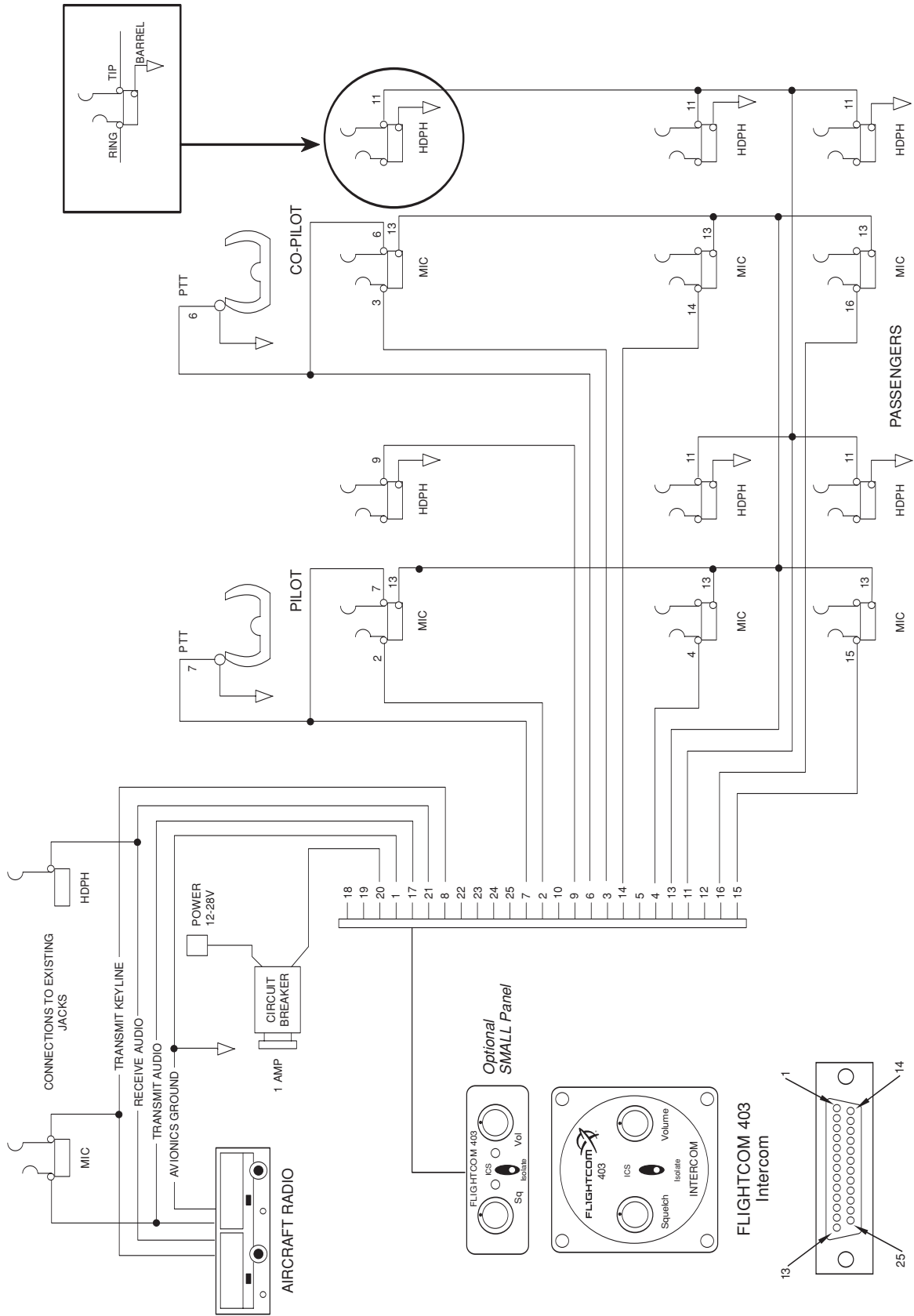

NOTES: Auxiliary input is pin no.18.
Isolate all mic jacks from airframe.

Rear view (Solder Terminal Side) of 25 pin D-sub plug (male Pins)

Wiring Suggestions

To wire the 403 and 403d intercoms:

1. Using a 25 watt soldering iron and 20 or 22 gauge Teflon-coated wire, make solder connections that are insulated with heat shrink tubing (**page 6, Figure 8**) and (**page 4, Figure 6**) for connector pin numbers and connection information.
2. Carefully route all wires away from aircraft controls, so that wires do not chafe on or come in contact with control cables, push rods, trim actuators, chains, flap followers, or other moving devices, and:
 - Avoid bundling wires with an RF inverter, coaxial cables, or synchro wiring.
 - Use shielded wire for microphone, headphone, and audio wiring.
 - Connect the intercom power lead (pin 20) to a circuit breaker on the Avionics Power Bus, not to the Flight Instrument Power.
 - Avoid circuits with motors, strobes, or other “noisy” devices.

NOTE: numbers are located on the solder terminal side of the 25-pin D-sub connectors.

If you are not sure where to obtain power, consult with an avionics shop before continuing.

Wire Connection Code

The connector pin numbers indicated in the following table correspond to the numbers on the D-sub connector included with the 403 and 403d intercoms.

Connector Pin #	Intercom Function	Aircraft Connection
1	Ground	Avionics ground point
2	Mic Audio	Pilot
3	Mic Audio	Co-pilot
4	Mic Audio	Navigator or Passenger #1
5	Navigator Key	Navigator PTT switch
6	Co-pilot Key	Co-pilot PTT switch
7	Pilot Key	Pilot PTT switch
8	Xmit Key	Com radio keyline
9	ICS Audio A	Pilot headphone
10	ICS Audio B	Pilot headphone
11	ICS Audio A	Passenger headphones
12	ICS Audio B	Passenger headphones
13	Mic Return	All mic jacks
14	Mic Audio	Passenger #2
15	Mic Audio	Passenger #3
16	Mic Audio	Passenger #4
17	Xmit Audio	Com radio
18	Aux Input A	Music system
19	Aux Input B	Music system
20	Power In	12 to 28 volts, 1 amp breaker
21	Recv Audio	NavCom or Audio panel
22	DCR Power	DCR indicators
23	Active LED	Amber LED
24	Start	Start button
25	Record	Play/Record switch (Red LED)

The stereo connection schematic includes a third person radio transmit connection. Delete the connection to pin number 5 when only installing a two-place radio transmit system, which is the most common pilot/co-pilot configuration (**page 4, Figure 6**).

Push-to-Talk Switch Options

If your aircraft does not have a built-in push-to-talk (PTT) switch, you will need to insert a portable PTT switch into another microphone jack that is parallel with the pilot's microphone jack. Flightcom Portable PTT Switch (part number 103-0604-10) is designed specifically for the 403 and 403d intercoms.

To connect Flightcom's Portable PTT Switch to either the 403 or 403d intercom:

1. Insert the PTT plug into the microphone jack.
2. Insert a headset microphone plug into the PTT inline jack.

To enable the co-pilot to transmit over the radio, connect the wire from pin 6 of the D-sub connector to one of the following:

- An existing co-pilot PTT switch
- The hand microphone jack, with the portable PTT switch plugged into that jack

Pin 6 may be left unconnected if co-pilot access to the radio is not necessary.

Installing Stereo Input and Output Jacks

If a music source has not been permanently installed in the aircraft, you can install a 3.5 mm stereo mini jack in an accessible location, to provide an interface for a portable stereo recorder or CD player.

Pin numbers 18 and 19 are points of attachment for auxiliary input that will enable listening to another audio source such as a tape player (page 4, Figure 6 and Figure 9 below).

To record from the intercom system, install a second 3.5 mm jack, and connect that jack by installing a 47 K resistor in series to the pilot's headphone output (pins 9 and 10).

CAUTION: do not combine both input and output functions on a single 3.5 mm jack.

Figure 9 - Connection to Stereo Inputs from Speaker Level (8 Ohm) Outputs

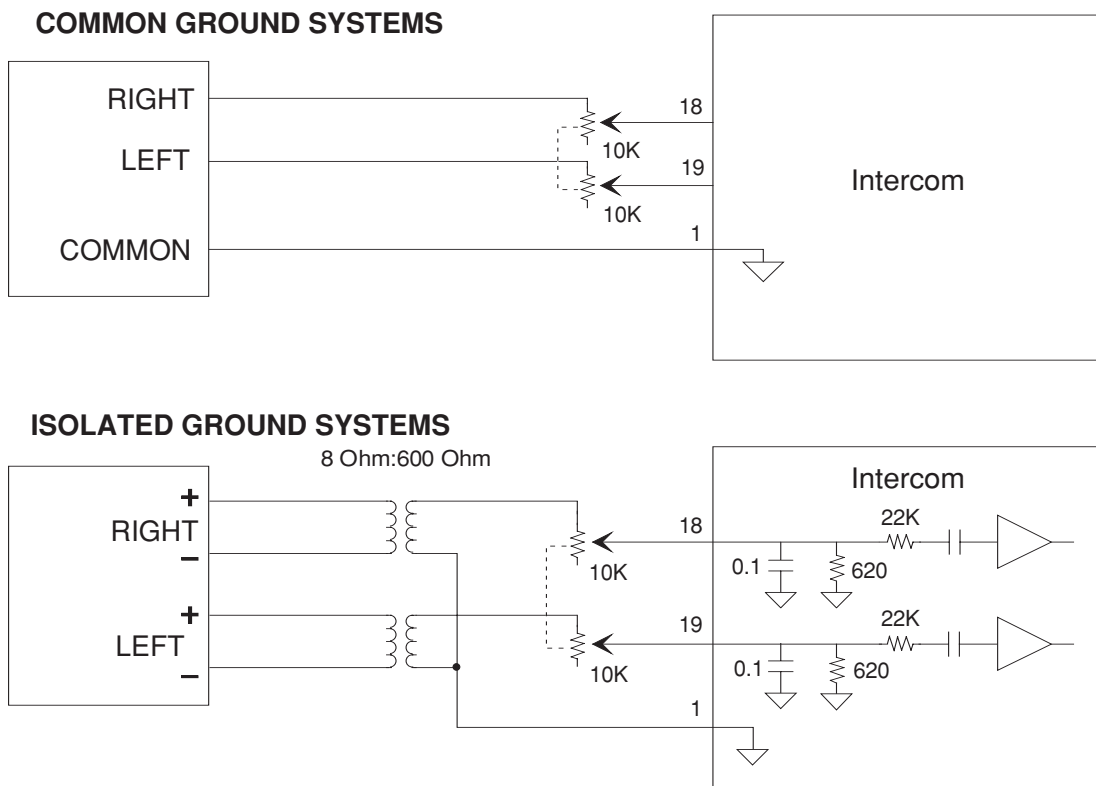

Potentiometers are dual 10K audio taper. Adjust for minimum distortion and good range of the volume control on the auxiliary audio source.

Case Top Removal

To open the Model 403 or 403d intercom case:

1. Remove the two hex screws at the rear of the intercom on either side of the 25-pin D-sub connector (DO NOT remove the screw on the side of the case). (Figure 10 below)
2. Loosen, but do not remove the two bushing nuts on the **Volume** and **Squelch** controls.
3. Carefully pry the top of the case upward, starting from the rear of the case at the 25-pin D-sub connector. The front of the top of the case fits snugly behind the panel end where the shafts protrude, and will require gentle but firm removal.
4. Carefully re-attach the top of the case.
5. Tighten the two bushing nuts.
6. Replace the two hex screws.

Figure 10 - Case Top Removal & DIP Switch Access

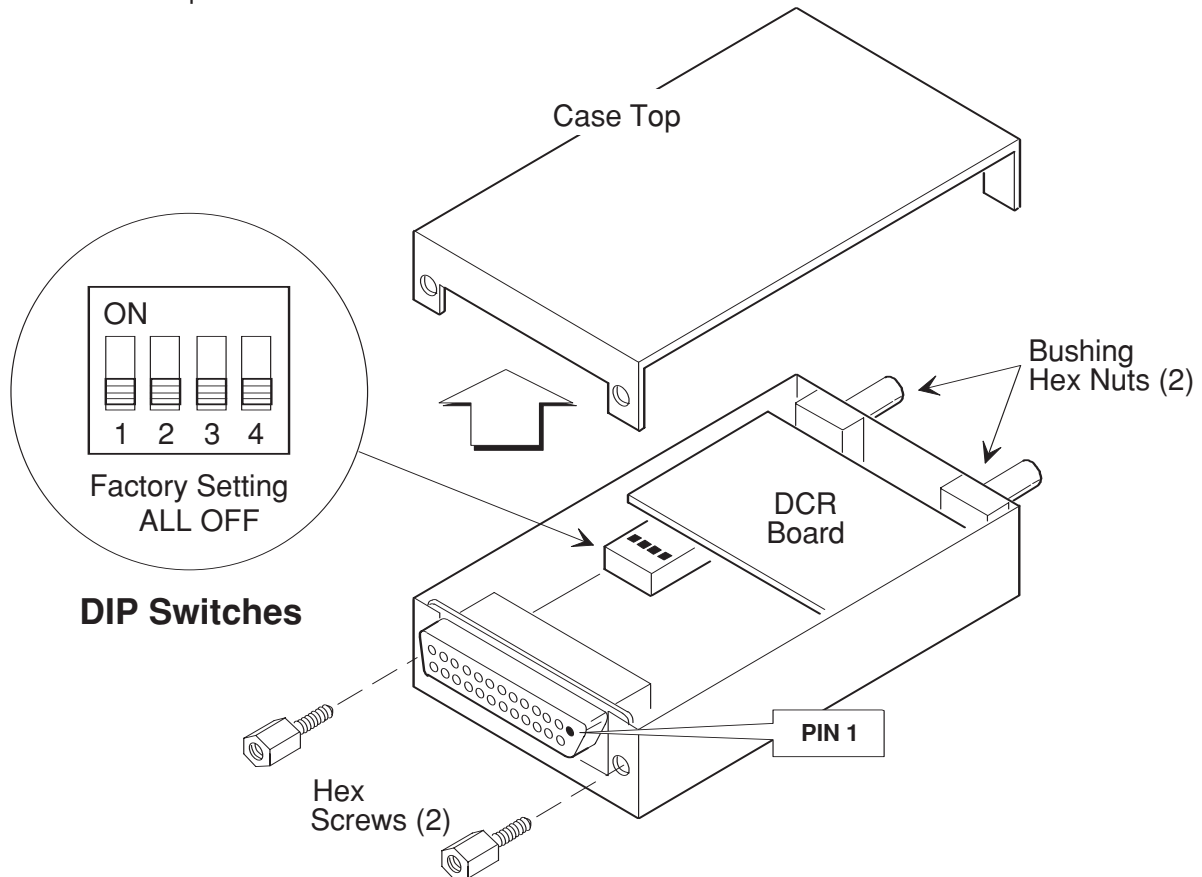

DCR™ Control Panel Installation

To install the DCR™ control panel:

1. Find a location for mounting the DCR™ control panel that is readily accessible for the pilot or radio operator.
2. Using the DCR™ control panel as a template to locate the six mounting holes, drill appropriate sized holes in the panel. The DCR™ control panel may be mounted either vertically or horizontally (page 10, Figure 11 and Figure 12).
3. Permanently secure the amber and red LEDs to the Control Panel with a small amount of strong glue on the back of each LED and LED holder.

By-Pass Plug Wiring

If you need to remove your intercom for service, install a by-pass plug, so that radio audio may be heard without the intercom (page 10, Figure 13).

Figure 11 - DCR™ Control Panel-Exploded View

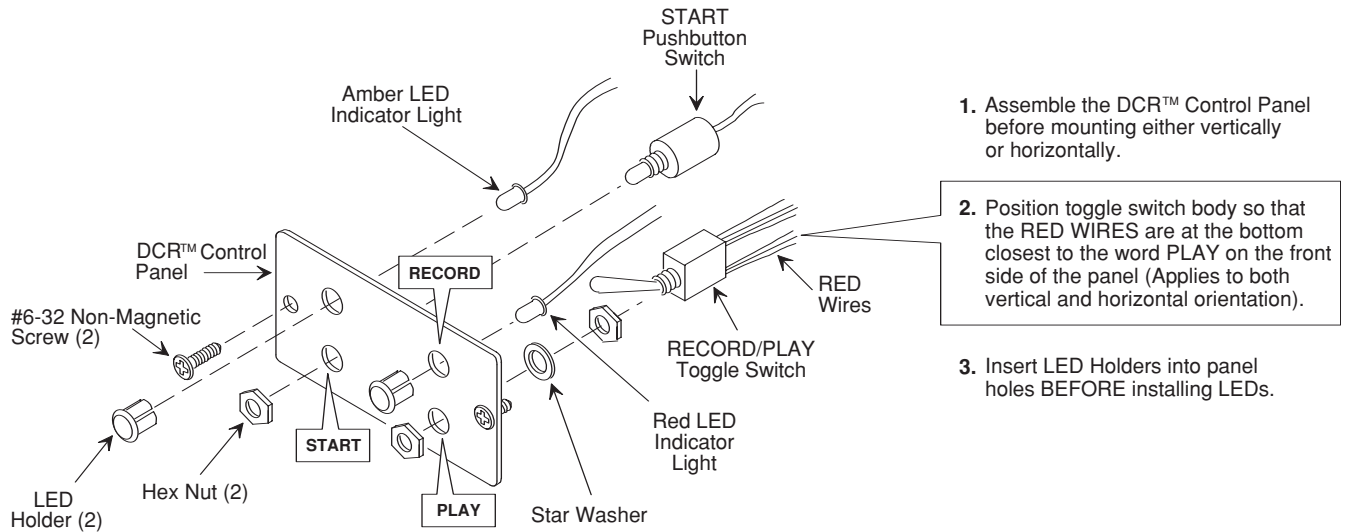

Figure 12 - DCR™ Control Panel

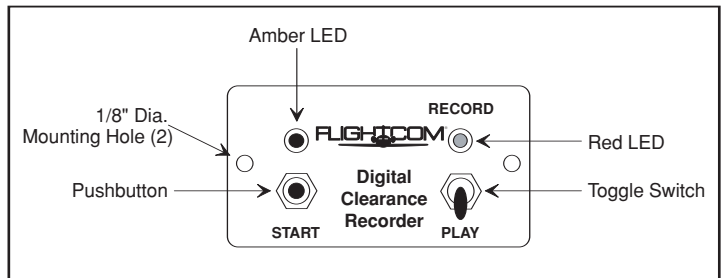
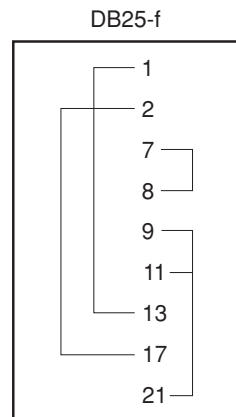

Figure 13 - By-Pass Plug Wiring Diagram



If you need to remove your intercom for service, follow this wiring diagram for a by-pass plug, so that radio audio may still be heard even when the intercom is removed.

OPERATING PROCEDURES

Adjusting the Intercom and Headsets

Models 403 and 403d are stereo intercoms, so use of stereo headsets will produce the finest sound reproduction.

To adjust the intercom and headsets:

1. Plug the headset into the pilot, co-pilot, or passenger jacks in the aircraft.
2. If you are using monaural headsets, place the toggle switch next to the headphone jack in the **Mono** setting.
CAUTION: if you are using monaural headsets and you do not place the toggle switch next to the headphone jack in the **Mono** setting, a squealing sound and possibly intercom damage will occur.
3. Turn on the aircraft master switch and avionics master switch to turn on the intercom.
4. Set the intercom **Volume** control knob to the 11 o'clock position.
5. Set the intercom **Squelch** control knob to the 3 o'clock position.
6. Turn up each headset volume control as far as possible.
7. Position the headset boom microphone 1/8" from your lips to the side of your mouth (**Figure 14 below**).
NOTE: noise canceling microphones will not operate correctly if they are more than 1/8" from the mouth.
8. While speaking loudly, adjust the headset volume control to a comfortable listening level.

Figure 14 - Correct Positioning of Boom and Microphone



Adjusting the Squelch Control

To adjust the squelch control:

1. While no one is talking, turn the intercom **Squelch** control knob as far clockwise as possible while still blocking background noise.
2. Re-adjust the setting in flight to compensate for different noise levels.

NOTE: if you set the squelch too high by turning the Squelch control knob counterclockwise, your voice will be cut out unless you talk very loudly; if you set the squelch too low by turning the Squelch control knob clockwise, the background noise will be heard occasionally.

The intercom will not interfere with normal use of the radio and will allow passengers to hear the aircraft radio and sidetone.

Radio Transmission

To transmit on the radio as the pilot or co-pilot, push the PTT switch associated with your headset. Only the person whose push-to-talk switch is depressed will be heard over the radio, so that an instructor can talk to a student pilot over the intercom while the student is transmitting over the radio without the instructor's voice being transmitted.

NOTE: if your push-to-talk switch fails, you can use an existing handheld microphone to talk on the radio while listening over the intercom.

Pilot Isolate Switch

For normal intercom and transmit operations, place the **Isolate** switch in the **ICS** position (Figure 15 below).

To isolate the pilot from intercom conversation, DCR™, and music and connect the pilot directly to the aircraft radio, place the **Isolate** switch in the **Isolate** position. Placing the Isolate switch in this position will also prevent passengers from hearing aircraft radio receptions and pilot transmissions to ATC while allowing them to continue to use the intercom, including the music source.

Figure 15 - Large Intercom Control Panel Showing Pilot Isolate Switch

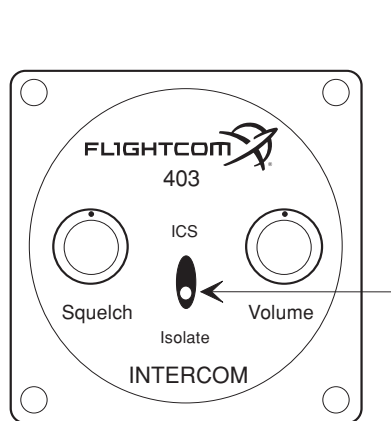

Intercom Failsafe Feature

In the event of a power supply interruption to the intercom, the integral failsafe relays in the intercom will connect the pilot's headset directly to the aircraft radio.

The power-off default is a monaural only feature. When using stereo headsets, such as the Flightcom 4DX or F20, set the headset switch to Mono. Using headsets with a stereo headphone plug but without a Mono setting will cause only one earphone to be active in the no-power default mode.

Music Muting

When you talk on the intercom or receive communication from the aircraft radio, an automatic instant muting feature will prevent interference with critical voice communications by reducing the auxiliary input volume. When intercom or radio conversation ends, the muting feature will deactivate to restore full music volume.

If you do not wish to have intercom conversations interrupt music, you can partially disable the instant muting feature by carefully removing the intercom case top and setting **DIP** switch **4** to the **ON** position (page 9, Figure 10).

NOTE: radio conversation will interrupt music even when the instant muting feature is disabled.

Using the DCR™ with Model 403d

The DCR™ is a 1 megabit voice-memory card that provides up to 32 seconds of digital recording with multiple instantaneous replays of ATC instructions or verbal check-point notes stored in memory. You will find this feature helpful in IFR conditions, while instructing, or anytime you wish to instantly recall voice information.

NOTE: the DCR™ is connected to the intercom, so using the Pilot Isolate feature will prevent the pilot from using the DCR™ until the **Isolate** switch is returned to the **ICS** position.

Making a New Recording

To record using the DCR™:

1. Set the toggle switch to **RECORD**.
2. Press the **START** button.

The red LED will confirm that you are set to the recording mode, while the amber LED will indicate that the DCR™ has been activated.

Making a New Recording to Replace a Previous One

To make a new recording to replace a previous one:

1. Set the toggle switch to **PLAY** and then back to **RECORD**.
2. Press the **START** button.

Stopping a Recording

To stop recording before the 32 second time limit is reached, set the toggle switch to **PLAY**.

Playing Back a Recording

To play back a recording:

1. Set the toggle switch to **PLAY**.
2. Press the **START** button.

The recording will replay each time you press the **START** button.

Stopping Playback before the End of a Message

To stop playback before the end of a message:

1. Set the toggle switch to **RECORD**.
2. Quickly return the toggle switch back to **PLAY**.

Erasing a Recording

To erase a recording:

1. Set the toggle switch to **RECORD**.
2. Press the **START** button.

Disconnecting power will also erase a recording.

NOTE: the DCR™ may be left idle and ready in either **RECORD** or **PLAY** mode.

TROUBLESHOOTING

Problem: you are having difficulty transmitting on the radio.

Reason: the pilot's and co-pilot's microphone jacks may have been incorrectly wired.

Solution: check wires **2, 3, 7, 8,** and **17**, and re-wire if necessary.

Problem: the sidetone is distorted while transmitting on the radio, even though the tower receives you loud and clear.

Reason: a distorted sidetone while transmitting may be due to improper shielding of the aircraft antenna cable.

Solution: have a radio technician check the shielding of the antenna cable.

Problem: you do not hear a sidetone while transmitting on the radio.

Reason: the radio sidetone level may be adjusted too low or turned off.

Solution: increase the radio sidetone output.

Reason: the radio may not have been designed with a sidetone output or the sidetone output may not have been connected during radio installation.

Solution: set **DIP** switches **1, 2,** and **3** to the **ON** position to allow the intercom to artificially generate a sidetone when you transmit (see Case Top Removal on page 9 of this manual for location of DIP switches inside the intercom case).

NOTE: when DIP switch **1** is in the **ON** position and the **Isolate** switch is in the **Isolate** position, the pilot will not hear his sidetone while transmitting, but passengers will be able to monitor his transmissions. The "receive" functions, however, will work normally, as described in the Pilot Isolate Switch section on page 12 of this manual.

Problem: the unit is completely dead.

Reason: there may not be voltage available through the power supply lead (pin 20).

Solution: restore voltage by reconnecting pin 20.

Reason: the fuse or circuit breaker may not be intact.

Solution: repair or replace the fuse or circuit breaker.

Reason: one or more wires may have been incorrectly numbered during installation, causing incorrect wire connection.

Solution: re-connect wires as shown in Figure 7 on page 5 or Figure 6 on page 4.

Reason: the headphones may not be plugged in all the way.

Solution: securely plug in the headphones.

Reason: the headset volume may not be turned up.

Solution: turn up the headset volume.

Reason: the headphone plugs may be corroded.

Solution: shine up the headset plugs with steel wool or crocus paper.

Reason: the aircraft master switch may be turned off.

Solution: turn on the aircraft master switch.

Reason: the squelch may not be set correctly (the 403 and 403d intercoms are silent when muted).

Solution: reset the squelch control.

Problem: there is a high pitch whine that varies with engine RPM.

Reason: the microphone jacks may not have been insulated from the aircraft frame when the intercom was installed.

Solution: insulate all microphone jacks from the aircraft frame.

Reason: a separate ground wire may not have been installed from each microphone jack to pin 13 on the intercom.

Solution: install a separate ground wire to pin 13 from each microphone jack.

Reason: the ground lead from pin 1 on the intercom may not be connected to the avionics ground.

Solution: attach the ground lead from pin 1 on the intercom to the avionics ground.

Reason: if the noise is very loud, a commercial alternator noise filter may need to be installed in series with the intercom power lead.

Solution: install a commercial alternator noise filter in series with the intercom power lead.

Reason: a diode in the alternator may be defective.

Solution: replace the diode.

Reason: the aircraft battery may need to be replaced.

Solution: replace the aircraft battery.

Problem: a high pitch whine or squeal is always present.

Reason: if the noise is coming from the turn and bank indicator or other electric gyro, the system may be incorrectly connected to the flight instrument power breakers.

Solution: connect the intercom power to the avionics power bus.

Reason: if the noise is coming from the turn and bank indicator or other electric gyro, the intercom may not be insulated from the airframe.

Solution: do the following:

1. Insulate all microphone jacks from the aircraft frame, and run a separate ground wire from each jack to pin 13 on the intercom.
2. Be sure the ground lead from the intercom is connected to an avionics ground wire.

Reason: if using a monaural headset, the switch next to the headphone jack may be in the Stereo setting.

Solution: switch to the **Mono** setting.

Reason: if using a stereo-capable headset, the Mono/Stereo switch on the headset may be in the Mono setting.

Solution: switch to the Stereo setting.

Problem: the intercom is not loud enough, or you lose parts of your sentences.

Reason: you may not have placed the microphone close enough to your lips.

Solution: place the microphone 1/8 inch from your lips to the side of your mouth.

Reason: the squelch may be adjusted too high.

Solution: while no one is talking, slowly rotate the **Squelch** control knob counterclockwise until you hear background noise, and then rotate the knob clockwise until the noise just disappears.

Reason: your headset may not be putting out a strong enough signal.

Solution: adjust the microphone pre-amp located on the headset microphone or in the earcup to equalize the sensitivity of your headset.

Problem: you are unable to squelch out all background noise.

Reason: if you are using a David Clark H10-30 headset, the microphone pre-amp may not be turned down.

Solution: rotate the small nylon screw at the front of the microphone completely counterclockwise to decrease the microphone pre-amp output.

Reason: if you are using single earsets or other tubular microphone type headsets, they may not have the noise canceling capability necessary for proper squelch control.

Solution: select a headset with a full earmuff and a high quality noise canceling electret microphone or amplified microphone.

Problem: the background noise level is too high while speaking.

Reason: the microphone you are using may have poor noise-canceling capability (only one poor microphone will make the entire system noisy).

Solution: switch to a premium headset with a small electret element, such as the Flightcom 5DX. As an alternative, turn down the volume control on your headset until the noise is at an acceptable level, and speak louder with the microphone touching your lips to increase the signal-to-noise ratio by increasing the strength of your voice and decreasing the apparent strength of the noise.

Problem: the intercom still does not work.

Reason: the problem may be within the radios and/or headsets.

Solution: check the radio and headsets in another aircraft.

If the intercom does not work after all attempts to correct a problem, contact us by phone, letter, or through our web site. Include the model number, a detailed description of the problem, and your name and contact information.

Do not return the unit without first contacting us. Usually the problem is due to installation or operation of the intercom.

PROCEDURE FOR WARRANTY CLAIM

To submit a warranty claim for repair:

1. Contact Flightcom at 503-684-8229, choose the Service option from the phone menu, and we will issue an RMA number, which is required to process your warranty claim.
2. Package the intercom securely to avoid damage in shipment.
3. Enclose a copy of the purchaser's original, dated bill of sale as proof of purchase.
4. Enclose a note describing the problem, the type of aircraft and headsets used, and the number of hours the intercom has been in use.
5. Write the RMA number on the outside of the box.

NOTE: Units must be shipped to us with freight prepaid.

FLIGHTCOM CORPORATION

7340 S.W. Durham Road, Portland, Oregon 97224

800-432-4342

503-684-8229

503-620-2943 Fax

www.flightcom.net

WARRANTY

Two-Year Intercom Limited Warranty to Original Purchaser

Flightcom Corporation warrants to the original purchaser of this product that it will be free from defects in materials and workmanship, under normal and proper use, for the period of two years from date of purchase. Flightcom Corporation will repair or replace, at its sole option, any parts showing factory defects during this warranty period, subject to the following provisions. This warranty applies only to a new product which has been sold through authorized channels of distribution. All work under warranty must be performed by Flightcom Corporation. All returned products must be shipped to our address, freight prepaid, accompanied by a dated proof of purchase. **SAVE YOUR SALES SLIP!** The purchaser voids this warranty if he, she or others attempt to repair, service or alter the product in any way. This warranty does not apply in the event of accident, abuse, improper installation, unauthorized repair, tampering, modification, fire, flood, collision or other damage from external sources, including damage which is caused by user replaceable parts (leaking batteries, etc.). This warranty does not extend to any other equipment or aircraft to which this product may be attached or connected. The foregoing is your sole remedy for failure in service or defect. Flightcom Corporation shall not be liable under this or any implied warranty for incidental or consequential damages, nor for any installation or removal costs or other service fees. This warranty is in lieu of all other warranties, express or implied, including the warranty of merchantability or fitness for use, which are hereby excluded. To the extent that this exclusion is not legally enforceable, the duration of such implied warranties shall be limited to two years from date of purchase. No suit for breach of express or implied warranty may be brought after two years from date of purchase.



Flightcom Corporation

7340 SW Durham Road, Portland, OR 97224 USA
www.flightcom.net • Phone: 503-684-8229 • Fax: 503-620-2943

Flightcom is a registered trademark of Flightcom Corporation.
Specifications subject to change without notice. ©2007 Flightcom Corporation.